

AIR1-AAD XHP

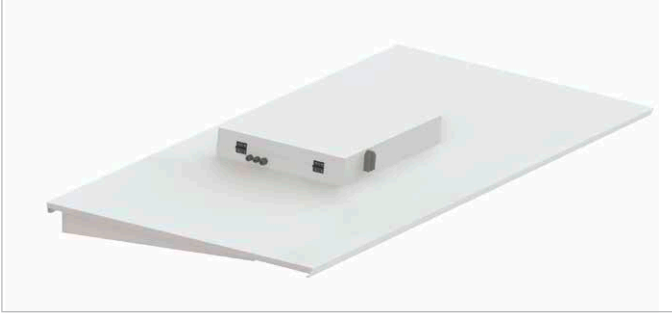

AIR1-AAD XH



Weather protection cover for the unit

Weather protection cover for the external installation of AIR1 ventilation units. Made of galvanised steel sheet, in weather-resistant design/coating. Increases the protection class of the unit to IP54.

Dimensions AIR1-AAD XHP 750 - 2500

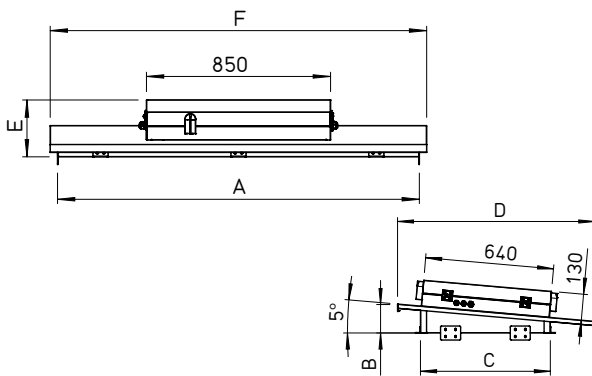

Dimensions in mm

AIR1 XHP 750 – 2500

Dimensions

Type	Ref. no.	A	B	C	D
AIR1-AAD XHP 750	40556	1667	144	698	984
AIR1-AAD XHP 1000	40567	1805	147	756	1044
AIR1-AAD XHP 1500	40580	1944	150	771	1059
AIR1-AAD XHP 2500	40591	2455	150	761	1046

Type	Ref. no.	E	F
AIR1-AAD XHP 750	40556	263	1739
AIR1-AAD XHP 1000	40567	263	1877
AIR1-AAD XHP 1500	40580	266	2014
AIR1-AAD XHP 2500	40591	266	2527

Dimensions AIR1-AAD XH 1000 - 3500

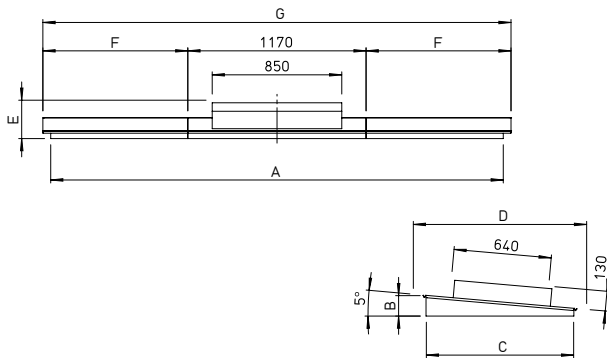

Dimensions in mm

AIR1 XH 1000 – 3500

Dimensions

Type	Ref. no.	A	B	C	D
AIR1-AAD XH 1000	06305	2005	106	635	805
AIR1-AAD XH 1500	06306	2085	106	643	812
AIR1-AAD XH 2500	06315	2346	125	865	1035
AIR1-AAD XH 3500	06316	2970	134	967	1137

Type	Ref. no.	E	F	G
AIR1-AAD XH 1000	06305	238	469	2105
AIR1-AAD XH 1500	06306	238	509	2187
AIR1-AAD XH 2500	06315	275	639	2448
AIR1-AAD XH 3500	06316	252	951	3072

Dimensions AIR1-AAD XH 4500 - 8500

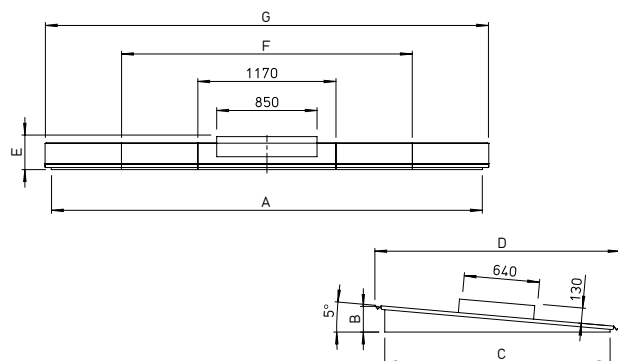

Dimensions in mm

AIR1 XH 4500 – 8500

Dimensions

Type	Ref. no.	A	B	C	D
AIR1-AAD XH 4500	06347	3515	142	1050	1218
AIR1-AAD XH 5500	06349	3555	160	1260	1428
AIR1-AAD XH 7000	06350	3605	185	1560	1728
AIR1-AAD XH 8500	06378	3650	218	1910	2078

Type	Ref. no.	E	F	G
AIR1-AAD XH 4500	06347	256	2395	3620
AIR1-AAD XH 5500	06349	265	2415	3660
AIR1-AAD XH 7000	06350	278	2440	3710
AIR1-AAD XH 8500	06378	293	2463	3755