

AIR1-AAD KR KW + DX XHP



AIR1-AAD KR KW + DX XH



■ Weather protection cover for external cold water or direct evaporator cooling registers

Weather protection cover for the external installation of external cold water or direct evaporator cooling registers.

Made of galvanised steel sheet, in weather-resistant design/coating. Increases the protection class of the cooling register to IP54.

Dimensions AIR1-AAD KR KW + DX XHP

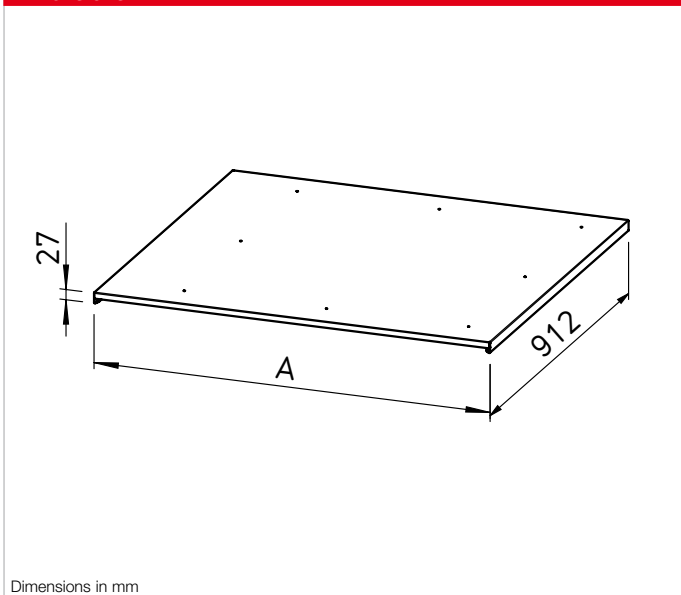

Dimensions in mm

Dimensions AIR1-AAD KR KW + DX XH

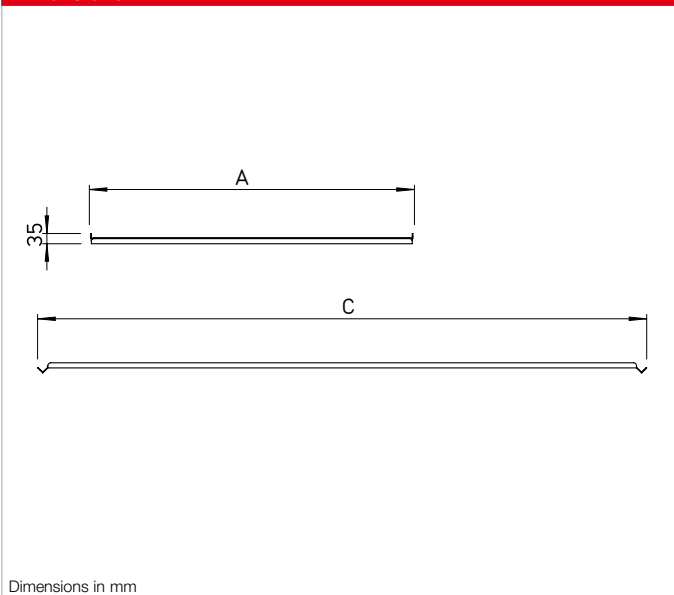

Dimensions in mm

■ Dimensions

Type	Ref. no.	A
AIR1-AAD KR KW + DX XHP 750	40557	984
AIR1-AAD KR KW + DX XHP 1000	40568	1044
AIR1-AAD KR KW + DX XHP 1500	40581	1059
AIR1-AAD KR KW + DX XHP 2500	40592	1043

■ Dimensions

Type	Ref. no.	A	C
AIR1-AAD KR KW + DX XH 1000	06451	1000	805
AIR1-AAD KR KW + DX XH 1500	06455	1000	812
AIR1-AAD KR KW + DX XH 2500	06461	1000	1031
AIR1-AAD KR KW + DX XH 3500	06462	1110	1138
AIR1-AAD KR KW + DX XH 4500	06463	1110	1220
AIR1-AAD KR KW + DX XH 5500	06464	1110	1430
AIR1-AAD KR KW + DX XH 7000	06465	1110	1730
AIR1-AAD KR KW + DX XH 8500	06466	1110	2080