

**AIR1-NH WW RH**



■ Hot water auxiliary heater

For demand-oriented temperature control of supply air. Further accessories are required for supply air temperature control (Hydraulic unit WSHS HE 24 V).

**Internal up to RH 3000:** For installation in the ventilation unit. The heating elements consist of copper piping with formed aluminium fins, and copper pipe water connections for flow and return.

**External from RH 5000:** For mounting directly to the supply air duct of the ventilation unit including fixing material. Casing in robust panel construction, insulated on all sides with 50 mm mineral wool for the minimisation of heat losses. External corrosion-resistant coating of casing. Large inspection openings on both sides of unit for easy access and optimised cleaning and maintenance. For internal and external installation. Note: A weather protection cover is required for external installation.

Detailed calculations / technical information: [www.AIR1Select.com](http://www.AIR1Select.com)

■ Technical data

	Type	Ref. no.	Heating capacity (1)	Water content	Weight (2)	Connection flow / return (3)	Temperature control system	Ref. no.
internal	AIR1-NH WW RH 1500	03805	7.6 kW	1.3 l	4.6 kg	G 1/2	WHS HE 24 V (0 – 10 V)	08318
	AIR1-NH WW RH 2000	03806	11.6 kW	1.7 l	5.8 kg	G 1/2	WHS HE 24 V (0 – 10 V)	08318
	AIR1-NH WW RH 3000	03824	14.9 kW	2.2 l	7.0 kg	G 1/2	WHS HE 24 V (0 – 10 V)	08318
external	AIR1-NH WW RH 5000	03825	24.1 kW	3.8 l	103.0 kg	G 1/2	WHS HE 24 V (0 – 10 V) M	06310
	AIR1-NH WW RH 6000	03826	30.5 kW	4.8 l	125.0 kg	G 3/4	WHS HE 24 V (0 – 10 V) M	06310
	AIR1-NH WW RH 8000	03827	45.2 kW	6.5 l	171.0 kg	G 3/4	WHS HE 24 V (0 – 10 V) M	06310
	AIR1-NH WW RH 9500	03830	53.7 kW	7.7 l	195.0 kg	G 1	WHS HE 24 V (0 – 10 V) L	06311
	AIR1-NH WW RH 12000	03831	67.1 kW	9.4 l	228.0 kg	G 1	WHS HE 24 V (0 – 10 V) L	06311
	AIR1-NH WW RH 15000	03833	80.5 kW	12.6 l	274.0 kg	G 1 1/4	WHS HE 24 V (0 – 10 V) L	06311

(1) at flow/return temperature 60/40°C, (2) without liquid, (3) external thread

**Dimensions AIR1-NH WW RH**

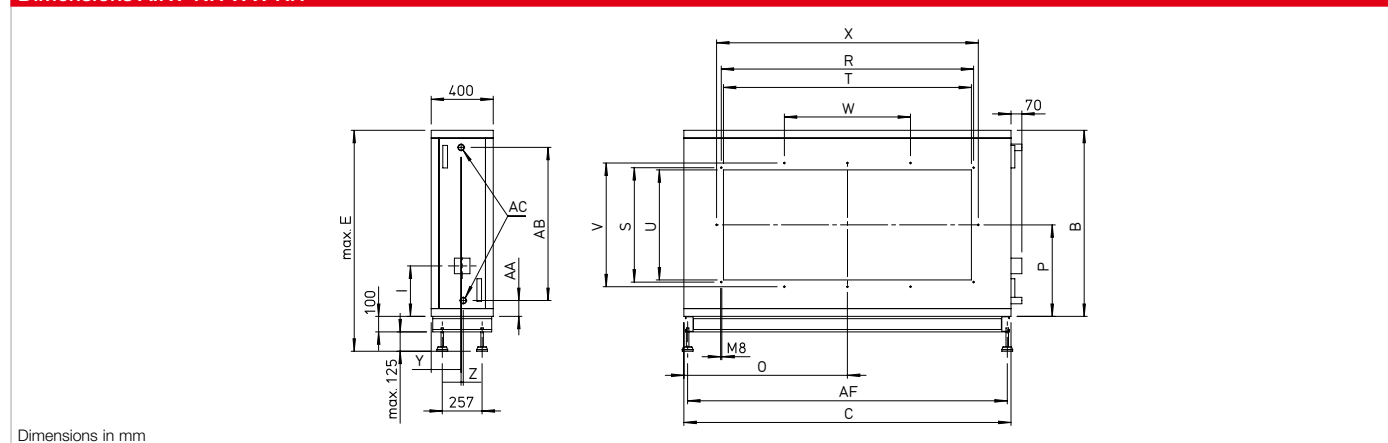

Dimensions in mm

■ Dimensions

	Type	Ref. no.	B	C	E	I	O	P	R	S	T
external	AIR1-NH WW RH 5000	03825	780	1240	1005	300	620	375	883	438	855
	AIR1-NH WW RH 6000	03826	830	1360	1055	300	680	400	883	438	855
	AIR1-NH WW RH 8000	03827	950	1610	1175	300	805	465	1083	438	1055
	AIR1-NH WW RH 9500	03830	1000	1710	1225	300	855	490	1228	438	1200
	AIR1-NH WW RH 12000	03831	1080	1860	1305	325	930	530	1503	538	1475
	AIR1-NH WW RH 15000	03833	1200	2110	1425	325	1055	590	1628	738	1600

	Type	Ref. no.	U	V	W	X	Y	Z	AA	AB	AC (1)	AF
external	AIR1-NH WW RH 5000	03825	410	498	–	–	178	35	85	599	G 1/2	1192
	AIR1-NH WW RH 6000	03826	410	498	–	–	188	27	93	631	G 3/4	1312
	AIR1-NH WW RH 8000	03827	410	498	361	–	188	27	93	752	G 3/4	1562
	AIR1-NH WW RH 9500	03830	410	498	409	–	178	33	93	802	G 1	1662
	AIR1-NH WW RH 12000	03831	510	598	501	1563	188	23	99	876	G 1	1812
	AIR1-NH WW RH 15000	03833	710	798	814	1688	193	14	102	988	G 1 1/4	2062

(1) External thread