

AIR1-VS



■ **Flexible connector**

Flexible connector (uninsulated), with flange connections on both sides, for mounting between the ventilation unit and duct system. Prevents structure-borne sound transmission and bridges mounting tolerances. Elastic fabric sleeve, operating temperature range from -10 °C to +80 °C.

Dimensions AIR1-VS

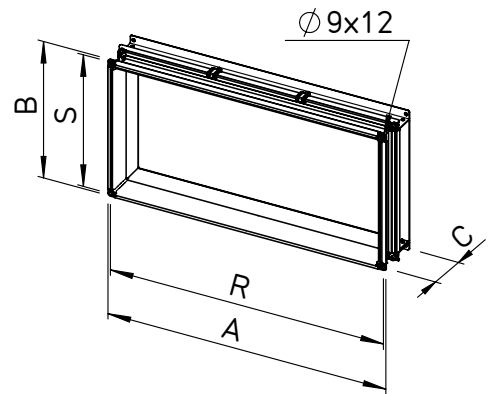

Dimensions in mm

■ **Dimensions**

RH units	Type	Ref. no.	A	B	C ¹⁾	R	S
AIR1-RH 1500	AIR1-VS 35/31	04372	396	356	145	378.3	338.3
AIR1-RH 2000	AIR1-VS 47/31	04373	516	356	145	498.3	338.3
AIR1-RH 3000	AIR1-VS 58/41	04374	626	456	145	608.3	438.3
AIR1-RH 5000	AIR1-VS 85/41	04375	901	456	220	883.3	438.3
AIR1-RH 6000	AIR1-VS 85/41	04375	901	456	220	883.3	438.3
AIR1-RH 8000	AIR1-VS 105/41	04376	1101	456	220	1083.3	438.3
AIR1-RH 9500	AIR1-VS 120/41	04377	1246	456	220	1228.3	438.3
AIR1-RH 12000	AIR1-VS 147/51	04378	1521	556	220	1503.3	538.3
AIR1-RH 15000	AIR1-VS 160/71	04379	1646	756	220	1628.3	738.3

1) max.

AIR1-ÜS XH / RH



■ **Square-round adapter**

Symmetrical adapter for connecting the ventilation unit to round air ducts/duct systems. Made of galvanised steel sheet. The pressure loss of the adapter at maximum air volume is < 10 Pa on both the intake and discharge side.

Dimensions AIR1-ÜS XH / RH

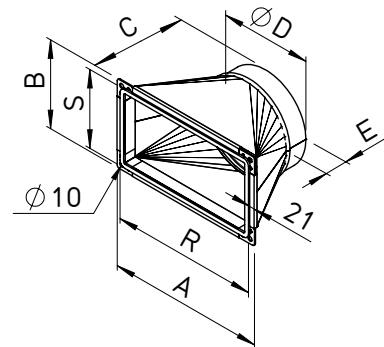

Dimensions in mm

■ **Dimensions**

Type	Ref. no.	A	B	C	D
AIR1-ÜS XH 1500/RH 1500	04367	400	360	200	315
AIR1-ÜS XH 2500/RH 2000	04368	520	360	250	400
AIR1-ÜS XH 3500-4500/RH 3000	04369	630	460	300	500
AIR1-ÜS XH 5500/RH 5000-6000	04370	905	460	350	630

Type	Ref. no.	E	R	S
AIR1-ÜS XH 1500/RH 1500	04367	60	378	338
AIR1-ÜS XH 2500/RH 2000	04368	80	498	338
AIR1-ÜS XH 3500-4500/RH 3000	04369	80	608	438
AIR1-ÜS XH 5500/RH 5000-6000	04370	80	883	438