

AIR1 XC 3200

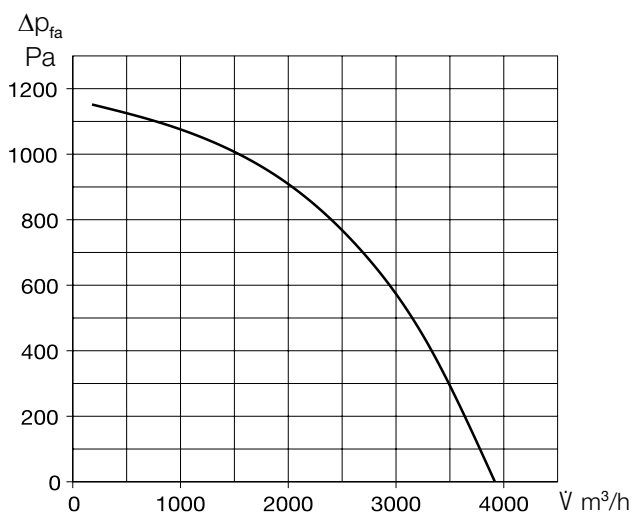

Performance curve AIR1 XC 3200



Unit type

	AIR1 XC 3200 L	AIR1 XC 3200 R
Ref. no.	04334	40119
Heat exchanger	Cross-counterflow	Cross-counterflow

Technical data

Mechanical data

Area of application	Inside
Installation position	Ceiling
Maintenance access	Side and underside
Min. air volume	520 m ³ /h
Max. air volume ERP	2,620 m ³ /h ⁽¹⁾
Max. air volume (free blowing)	3,850 m ³ /h
Weight, unit operational	370 kg
Housing class (DIN 1886)	T2 / TB2 / D2
Filter Outside air	ISO ePM ₁ 55% (F7) ⁽²⁾
Filter Extract air	ISO ePM ₁₀ 50% (M5) ⁽²⁾
Media temperature (air)	-20 to +50 °C
Ambient temperature (place of installation)	0 to +50 °C
Protection class	IP31

Electrical data

Central building control system	BACnet, Modbus TCP/IP
Voltage / Frequency	400 V 3N ~, 50 Hz
Max. output Fans	2 x 1,300 W
Max. output Elec. pre-heater	10,500 W
Nominal current	
– Ventilation unit	20.9 / 20.9 / 15.5 A ⁽³⁾
– Electrical auxiliary heater	15.2 / 15.1 / 15.1 A ⁽⁴⁾
– max. total	36.1 / 36 / 30.6 A
Connection (wiring diagram no.)	1316

(1) = at 200 Pa external pressure loss ERP-compliant

(2) = Other filter classes see optional accessories

(3) = includes electrical pre-heater

(4) = Optional accessory

Sound data

Sound power level L_{WA} dB(A) at 250 Pa external pressure

	1,000 m ³ /h	2,200 m ³ /h	2,620 m ³ /h
Supply air (L _{WA})	69	78	82
Extract air (L _{WA})	54	63	67
Outside air (L _{WA})	55	64	68
Exhaust air (L _{WA})	69	79	83

Sound pressure level L_{pA} dB(A) of sound radiated from housing

	1,000 m ³ /h	2,200 m ³ /h	2,620 m ³ /h
Housing rad. 1 m	35	43	47
Housing rad. 3 m	25	33	38
Housing rad. 5 m	21	39	33

The sound power at the connectors is calculated for the simultaneous operation of both fans. The sound pressure level is determined for the simultaneous operation of both fans at distances of 1.3 and 5 m.

Dimensions AIR1 XC 3200 L

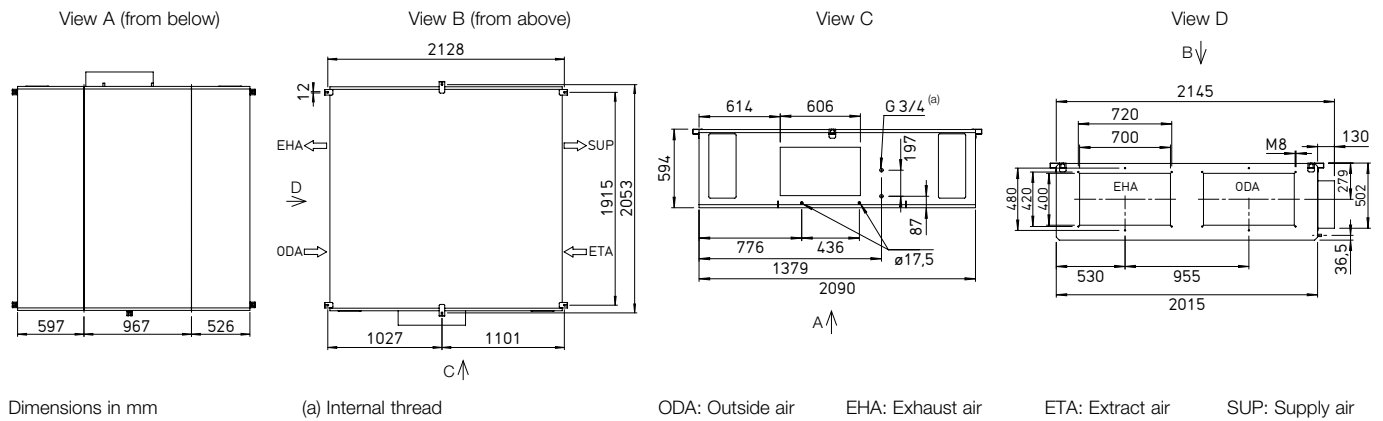

Dimensions AIR1 XC 3200 R

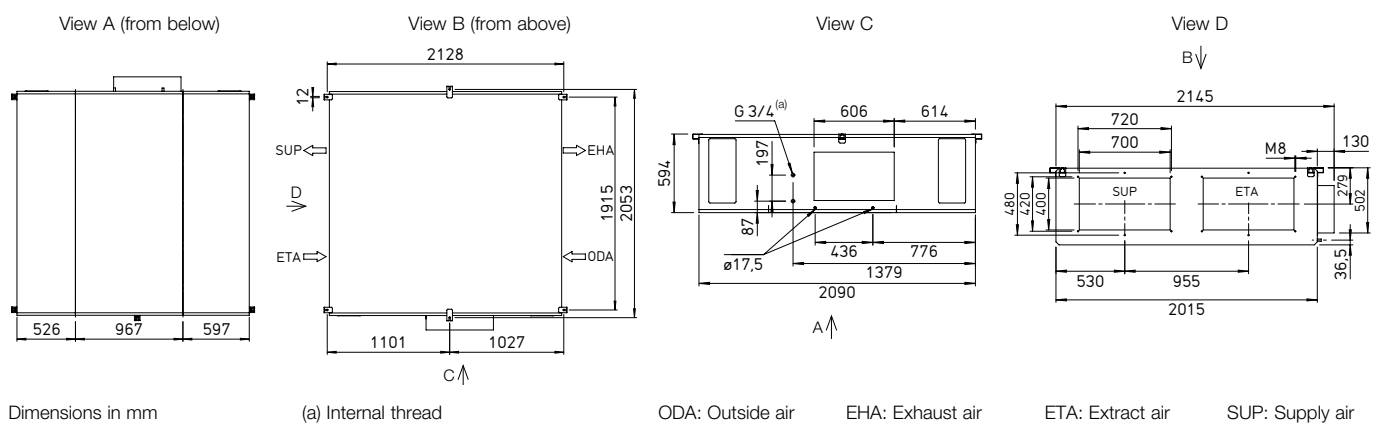

Accessories

Heating and cooling registers

Auxiliary heater

AIR1-ENH XC 3200 Electrical, internal	Ref. no. 02489	Page 94
AIR1-NH WW XC 3200 L Hot water, internal	Ref. no. 03663	Page 96
AIR1-NH WW XC 3200 R Hot water, internal	Ref. no. 40124	Page 96
Hydraulic unit for hot water heating register		
WHSB HE 24 V (0 – 10 V)	Ref. no. 08318	Page 96
Cooling register		
AIR1-KR KW XC 3200 L Cold water, external	Ref. no. 04190	Page 98
AIR1-KR KW XC 3200 R Cold water, external	Ref. no. 40129	Page 98
AIR1-CO DX XC 3200 L Change-over, external	Ref. no. 40368	Page 104
AIR1-CO DX XC 3200 R Change-over, external	Ref. no. 40373	Page 104
AIR1-SM DX (1) Control module	Ref. no. 40408	Page 110

Air routing

Multi-leaf dampers

AIR1-JVK XC 3200/XVP 3500	Ref. no. 06003	Page 111
Flexible connector		
AIR1-VS 70/40	Ref. no. 07408	Page 113
Potential equalisation cable		
PAK M8	Ref. no. 40812	Page 113
Adapter square-round		
AIR1-ÜS XC 3200/XVP 3500	Ref. no. 04365	Page 112

Condensate drainage

Condensate pump

AIR1-KP XC 2200-3200	Ref. no. 06868	Page 114
Ball siphon		
AIR1-KS D for use with ceiling mounted units and cooling register	Ref. no. 07170	Page 114

Controls

Controllers

AIR1-BE ECO	Ref. no. 06186	Page 119
AIR1-BE TOUCH	Ref. no. 06187	Page 119
Controller connection cable		
AIR1-SL 4/10 10 m	Ref. no. 07073	Page 119
AIR1-SL 4/20 20 m	Ref. no. 07121	Page 119

Sensors

AIR1/KWL-VOC 0-10V Mixed gas sensor	Ref. no. 20250	Page 119
AIR1/KWL-CO2 0-10V Carbon dioxide sensor	Ref. no. 20251	Page 119
AIR1/KWL-FTF 0-10V Humidity-temperature sensor	Ref. no. 20252	Page 119
AIR1-CO2 K Carbon dioxide sensor duct	Ref. no. 07124	Page 119

Signal converter for sensors

AIR1-SK	Ref. no. 06019	Page 120
----------------	----------------	----------

Extension kit for constant pressure control

AIR1-CAP	Ref. no. 06756	Page 120
-----------------	----------------	----------

Duct smoke detector with VdS approval

RMK	Ref. no. 04982	Page 120
------------	----------------	----------

Duct smoke detector with DIBt approval

KRM	Ref. no. 40825	Page 120
KRM-MK Mounting bracket for KRM	Ref. no. 40826	Page 120
KRM-G Protective housing	Ref. no. 40847	Page 120
KRM-MKG Mounting bracket for protective housing	Ref. no. 40848	Page 120

Air filters

Spare air filter and other filter classes

ELF-AIR1 XC 3200/ePM10 50%/96 (M5)	Ref. no. 02175	Page 121
ELF-AIR1 XC 3200/ePM1 55%/96 (F7)	Ref. no. 02226	Page 121
ELF-AIR1 XC 3200/ePM1 80%/96 (F9)	Ref. no. 02286	Page 121

The use of original spare air filters is mandatory to guarantee the specified technical data and air volumes.

(1) = Necessary accessory in connection with an AIR1-CO DX change-over register for connecting an AIR1 ventilation unit of the XC, XH and RH series to the control of an on-site cooling system.