

## EHR-K

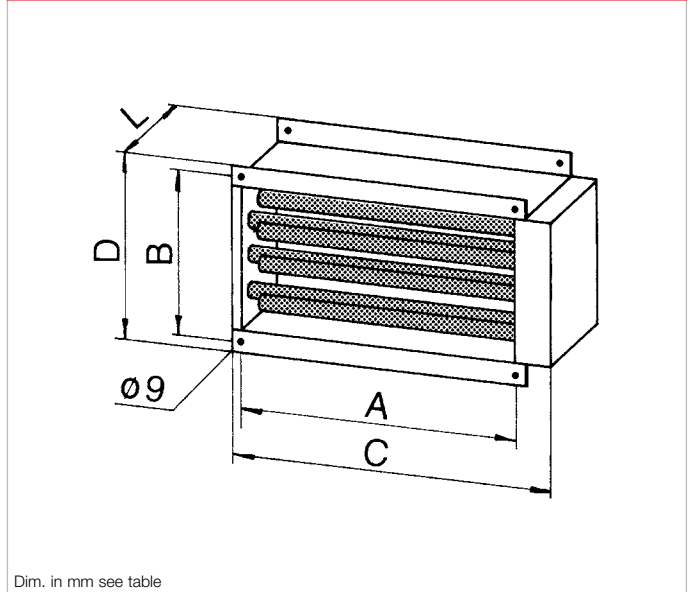

## Dimensions EHR-K



Dim. in mm see table

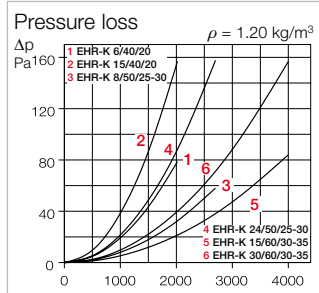
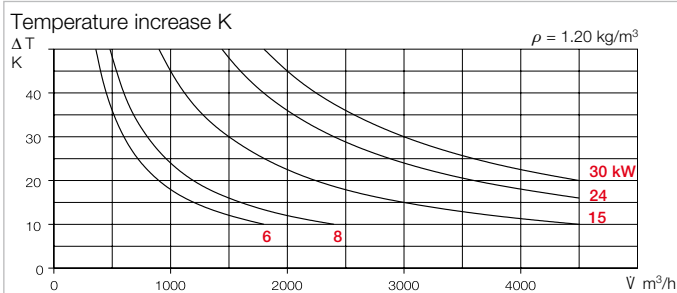

### Electric heating element EHR-K

- Closed tubular heating element in galvanised steel sheet casing with double-sided connection flanges for installation in duct system.
- Tubular heating element with low surface temperature wired to external terminal box, switchable in several groups.
- Equipped with an automatically resetting temperature limiter (activation temperature 90 °C) and a manually resettable temperature limiter (activation temperature 120 °C).
- Protection category IP40.

### Installation instructions

- Install the heating element in the flow direction downstream of the fan. In case of installation upstream of the fan, ensure that the air flow temperature at the fan does not exceed its maximum permissible temperature. A duct piece of at least 1 m in length must be installed between the fan and the heating element. The minimum heating element air volume must be maintained. The heating element must be connected so that operation is only possible when the fan is activated. If the temperature monitor is triggered, the heating element must deactivate automatically. The heating elements can be operated in groups by using appropriate wiring, so that the reduction of heat output is possible.

### Selection and operation

- Heating elements create additional pressure loss which must be taken into account for overall system dimensioning. An air flow temperature increase depends on the volume flow and heat output (see diagrams above). In order to prevent unwanted temperature monitor deactivation, the minimum air flow rate (see table) must be maintained.

### Accessories

#### Electronic temperature control system EHS

See type table  
Controls the heat output of the heating element depending on the difference between the setpoint and actual value for supply air temperature, which serves as a reference variable.

#### Duct sensor (Accessory for EHS) TFK

Ref. no. 05005  
Temperature sensor for detecting the air temperature in air ducts.

#### Room sensor (Accessory for EHS) TFR

Ref. no. 05006  
Temperature sensor with integrated setpoint adjuster for surface mounting. Also suitable simply as a temperature sensor or simply as a setpoint adjuster.

Type	Ref. no.	Power	Switch groups	Current consumption	Min. volume flow	Compat. with rect. duct fan	Connect. Wiring diagram <sup>1)</sup>	Dimensions					Weight approx.	Compatible temperature control system														
								A	B	C	D	L		kg	Type	Ref. no.												
														kW	x kW	A	m³/h	NG cm	No.									
<b>3-, 400</b>																												
EHR-K	6/40/20	08702	6	2 x 3	8.7	430	40/20	361.4	423	223	550	250	200	7.3	EHSD 16	05003												
EHR-K	15/40/20	08703	15	5 x 3	21.7	430	40/20	366.4	423	223	550	250	320	13.3	EHSD 16	05003												
EHR-K	8/50/25-30	08704	8	2 x 4	11.3	680	50/25-30	362.4	523	273/323	650	350	200	9.2	EHSD 16	05003												
EHR-K	24/50/25-30	08705	24	6 x 4	33.9	680	50/25-30	364.4	523	273/323	650	350	250	17.2	EHSD 30	05004												
EHR-K	15/60/30-35	08706	15	3 x 5	20.9	980	60/30-35	365.4	623	323/373	750	400	200	12.9	EHSD 16	05003												
EHR-K	30/60/30-35	08707	30	6 x 5	41.7	980	60/30-35	363.4	623	323/373	750	400	200	19.3	EHSD 30	05004												

<sup>1)</sup> Principle connection for all types No. 476.2.

### Accessories Page

Electronic temperature control system EHS 487

### Reference

DIN VDE 0100-420 must be observed on site; suitable air flow monitoring and electrical locking must be provided.