

General information

■ If the fan noise emission exceeds an acceptable level, passive noise reduction measures must be taken. For this purpose, silencers can be used according to the absorption principle. This silencer type ensures good sound insulation with low pressure losses.

Helios offers silencers which are optimally adapted to the Helios fans. Round duct and rectangular duct silencers are available in corresponding casing shapes. Of course, all silencer types can also be used with fans of other brands.

Helios silencers have casings made of galvanised steel sheet and they are provided with baffles made of high-quality mineral wool, which are covered with an abrasion-resistant fleece against the air flow.

**Technical information
Sound insulation**

■ The measure for sound insulation is insertion loss according to DIN EN ISO 14163. It shows the reduction in noise level in a round duct or rectangular duct piece with and without silencers determined by a comparison measurement.

For the measurement without silencers, a sound-reflecting piece is used instead. This determines the insertion loss:

$$D_b = L_o - L_m \text{ dB}$$

L_o : Level without silencer
 L_m : Level with silencer

Since the effects of a silencer are highly dependent on the frequency, the insertion loss depending on frequency is specified.

The damping of low frequency noises requires more damper volume than the damping of high frequency noises and is therefore associated with higher costs.

For these reasons, a knowledge of the fan noise spectrum (octave and third octave spectrum) is required for the selection of a silencer. When acoustically assessing a ventilation system, it should be noted that other system components, such as bends, cross-section changes

and branches also have a sound-insulating effect.

More detailed information can be found in VDI Guideline 2081 – noise generation and noise reduction in air-conditioning systems.

The lower limit for system noise emission is determined by the generation of flow noise in the silencer and in the system components. These increase significantly with increasing flow velocity. Therefore, the flow velocities should be kept as low as possible.

■ **Quick selection of a silencer**

An average insulation measurement is specified in the type table (red column far right) for the simple selection of round duct and rectangular duct silencers. This value should be deducted from the fan sound power level ($L_{WA \text{ tot.}}$). The result is the fan sound power level reduced by the sound insulation ($L_{WA \text{ reduc.}}$).

This selection method, which shows differences compared to the frequency band calculation, is based on rounding. A calculation according to the octave band (see adjacent example) produces more accurate values.

■ **Example:**
Available: Fan type VARD 225/2
Selected: Duct silencer RSD 225/600 (installation length = 600 mm)

Fan sound power level
 $L_{WA \text{ tot.}} = 81 \text{ dB(A)}$
Average silencer insulation measurement
minus = 15 dB(A)
= Reduced sound power level
 $L_{WA \text{ reduc.}} = 66 \text{ dB(A)}$

■ **Terms**
 $L_{WA \text{ tot.}}$ = Fan sound power level in dB(A) (from table above performance diagram).

Average insulation measurement = Derived damping capacity of the silencer in dB(A) (from red column in silencer type table).

$L_{WA \text{ reduc.}}$ = Sound power level reduced by silencer insertion in dB(A).

Sound level calculation

■ In order to calculate the sound level after insertion of a silencer, the insulation loss by frequency band must be deducted from the fan band level and the total sound level can then be calculated. This is normally done in octave bands. Multiple silencers with the same diameter can be arranged one behind the other for larger insertion losses. The example below explains the procedure. Given task: Noise reduction of fan type VARD 225/2 (2800 min⁻¹) using silencers RSD 225/600 (basic length 2).

	Octave mid-frequency Hz							dB(A)
	125	250	500	1000	2000	4000	8000	
A-weighted octave level $L_{WA, \text{Oct}}$ of fan VARD 225/2	51	62	74	76	76	72	63	
A-weighted total sound power level L_{WA}	$L_{WA} = 81 \text{ dB(A)}$							
Insertion loss of silencer D_b RSD 225/600 (2 x basic length)	4	10	17	27	25	17	14	
A-weighted octave level $L_{WA, \text{Oct}}$ of fan with silencer	47	52	57	49	51	55	49	
A-weighted total sound power level L_{WA}^* of fan with silencer	$L_{WA}^* = 10 \cdot \lg (10^{47 \cdot 0.1} + 10^{52 \cdot 0.1} + 10^{57 \cdot 0.1} + 10^{49 \cdot 0.1} + 10^{51 \cdot 0.1} + 10^{55 \cdot 0.1} + 10^{49 \cdot 0.1}) = 61 \text{ dB(A)}$							
Associated A-weighted sound pressure level at 1 m distance	$L_{pA}^* = 53 \text{ dB(A)}$							

KSD



Dimensions KSD

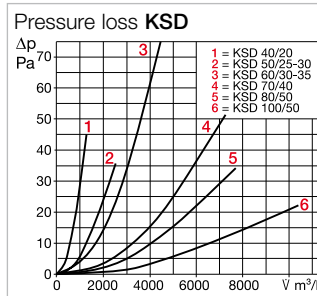
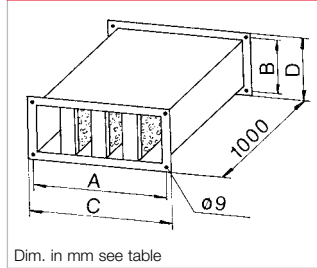

Rectangular duct silencer KSD

Design - Installation

Casing made of galvanised steel sheet, with connection flanges, dimensionally matched to the rectangular duct fans, for insertion on the inlet and outlet side of the rectangular duct system. The silencers upstream or downstream of the fan must be provided with a flexible connector (VS or VS Ex) to the further duct system to prevent structure-borne noise transmission.

Pressure loss

Rectangular duct silencers cause flow resistances (adjacent diagram) which must be taken into account for the design. These values apply for uniform flows. In case of non-uniform flows (e.g. for the outflow from rectangular duct fans), a straight duct piece at least 1 m in length must be used or allow for higher resistances.

Reference	Page
Selection - noise calculation	494

Type	Ref. no.	Nom. duct size in cm	No. links	Dimensions in mm				Weight approx. kg	Insulation loss D_e dB at Hz						Average loss	
				A	B	C	D		125	250	500	1000	2000	4000		8000
KSD 40/20	08728	40/20	3	420	220	443	240	13	8	11	23	31	31	26	18	17
KSD 50/25-30	08729	50/25-30	3	520	270/320	540	340	16.5	6	9	19	25	25	20	15	14
KSD 60/30-35	08730	60/30-35	4	620	320/370	640	390	20	7	10	21	28	28	23	16	12
KSD 70/40	08731	70/40	4	720	420	740	440	25	6	8	18	24	24	20	14	12
KSD 80/50	08732	80/50	5	820	520	840	540	31	7	9	19	26	26	21	15	14
KSD 100/50	08733	100/50	5	1020	520	1040	540	35	5	7	16	21	21	17	12	11

FSD



Dimensions FSD

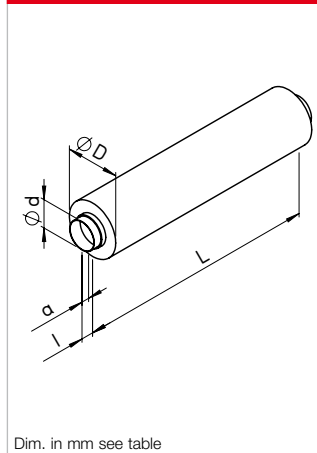

Flexible cross talk silencer FSD

Design - Installation

Robust design made of flexible aluminium duct. Perforated inner lining with resin-bonded sound insulation lining approx. 50 mm thick. Double-sided connectors, which can be inserted in the duct or connected to the fan or duct using a pipe clamp connector BM. The flexible design facilitates installation.

Pressure loss

Four times the friction resistance is taken into account for the system calculation.

Type	Ref. no.	L	Dimensions in mm				Insertion loss dB at Hz				Weight aprx. kg	Average loss
			Ø D	Ø d	a	l	250	500	1000	2000		
FSD 100	00676	1000	212	100	34	54	16	25	42	50	1.3	21
FSD 125	00677	1000	236	125	34	54	13	22	39	42	1.7	18
FSD 160	00678	1000	262	160	34	54	10	21	39	30	1.9	16
FSD 200	00679	1000	312	200	34	54	8	16	32	22	2.4	12
FSD 250	00680	1000	367	250	34	54	8	16	32	15	3	12
FSD 315	00681	1000	412	315	39	59	6	12	25	11	3.4	9
FSD 355	00682	1000	462	355	39	59	6	10	25	10	3.8	8
FSD 400	00683	1000	512	400	39	59	6	10	20	9	4.3	8

Reference	Page
Selection - noise calculation	494

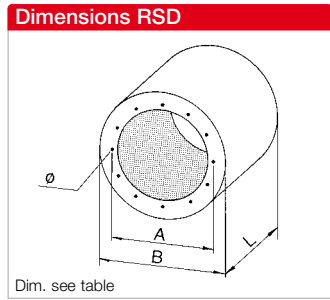

■ Insertion loss
Multiple silencers with the same diameter can be arranged one behind the other for larger insertion losses.

■ Pressure losses
The flow resistances of the RSD silencer are very low. Twice the friction resistance is taken into account for the system calculation.

■ Design – Installation
Casing made of galvanised steel sheet. Lining with high-quality mineral wool, which is equipped with a fleece on the flow side for protection against abrasion. The dimensions and fixing holes of all sizes are based on the standard fan diameter (R 20). The fixing holes correspond to DIN 24155, p. 2.

Reference	Page
Selection - noise calculation	494

Type Nominal Ø	Ref. no.	Basic length	Dimensions in mm				Weight approx. kg	Insertion loss D _e dB								Average loss
			L	A	B	Hole Ø		125	250	500	1000	2000	4000	8000		
RSD 225/300	08734	1	300	259	404	6 x M 6	7	2	5	9	14	13	8	6	8	
RSD 225/600	08735	2	600	259	404	6 x M 6	12	4	10	17	27	25	17	14	15	
RSD 225/900	08736	3	900	259	404	6 x M 6	17	7	13	25	33	31	20	16	20	
RSD 250/300	08737	1	300	286	404	6 x M 6	7	3	5	8	8	9	7	5	8	
RSD 250/600	08738	2	600	286	404	6 x M 6	12	5	10	16	24	19	14	10	15	
RSD 250/900	08739	3	900	286	404	6 x M 6	16	6	12	22	28	21	15	11	18	
RSD 280/400	08740	1	400	322	454	8 x M 8	10	4	5	8	14	9	8	6	8	
RSD 280/800	08741	2	800	322	454	8 x M 8	18	7	9	16	28	18	17	14	14	
RSD 280/1200	08742	3	1200	322	454	8 x M 8	25	9	12	23	37	23	20	16	18	
RSD 315/400	08743	1	400	356	504	8 x M 8	11	3	3	7	13	8	7	5	5	
RSD 315/800	08744	2	800	356	504	8 x M 8	19	6	8	14	26	16	12	9	12	
RSD 315/1200	08745	3	1200	356	504	8 x M 8	28	9	12	21	36	18	17	14	18	
RSD 355/400	08746	1	400	395	564	8 x M 8	13	3	4	7	11	7	6	4	6	
RSD 355/800	08747	2	800	395	564	8 x M 8	23	6	7	13	22	14	12	8	11	
RSD 355/1200	08748	3	1200	395	564	8 x M 8	33	8	11	17	29	18	15	10	17	
RSD 400/400	08749	1	400	438	564	12 x M 8	12	3	4	6	9	7	5	3	6	
RSD 400/800	08750	2	800	438	564	12 x M 8	21	6	6	12	18	13	12	8	9	
RSD 400/1200	08751	3	1200	438	564	12 x M 8	30	7	10	14	22	18	13	9	15	
RSD 450/400	08752	1	400	487	634	12 x M 8	17	4	5	8	10	8	7	5	8	
RSD 450/800	08753	2	800	487	634	12 x M 8	27	6	7	13	18	13	12	9	11	
RSD 450/1200	08754	3	1200	487	634	12 x M 8	38	8	10	18	23	17	14	10	15	
RSD 500/600	08755	1	600	541	714	12 x M 8	27	4	5	9	11	9	9	6	8	
RSD 500/900	08756	2	900	541	714	12 x M 8	36	6	8	14	16	13	13	9	12	
RSD 500/1200	08757	3	1200	541	714	12 x M 8	45	8	11	22	24	17	16	12	17	
RSD 560/600	08758	1	600	605	804	8 x M 10	32	3	5	9	9	8	8	6	8	
RSD 560/1200	08759	2	1200	605	804	8 x M 10	52	6	10	19	19	16	13	10	15	
RSD 630/600	08760	1	600	674	900	8 x M 10	44	3	5	8	8	8	7	5	8	
RSD 630/1200	08761	2	1200	674	900	8 x M 10	68	5	10	16	15	15	11	8	15	
RSD 710/600	08762	1	600	751	1000	8 x M 10	51	3	5	7	7	7	6	4	8	
RSD 710/1200	08763	2	1200	751	1000	8 x M 10	80	5	10	14	13	13	10	7	15	
RSD 800/600	08764	1	600	837	1100	12 x M 10	57	2	5	7	6	6	5	4	8	
RSD 800/1200	08765	2	1200	837	1100	12 x M 10	88	5	9	13	11	11	9	6	14	
RSD 900/900	08766	1	900	934	1220	12 x M 10	82	2	4	10	9	6	5	4	6	
RSD 900/1800	08767	2	1800	934	1220	12 x M 10	135	4	9	21	17	13	9	8	14	
RSD 1000/900	08768	1	900	1043	1350	12 x M 10	96	2	4	8	7	5	4	3	6	
RSD 1000/1800	08769	2	1800	1043	1350	12 x M 10	157	4	7	16	14	10	7	6	11	
RSD 1120/900	08770	1	900	1174	1350	12 x M 10	81	2	3	7	6	4	3	3	5	
RSD 1120/1800	08771	2	1800	1174	1350	12 x M 10	136	3	6	14	11	8	6	5	9	
RSD 1250/900	08772	1	900	1311	1460	12 x M 10	86	1	2	5	4	3	2	2	3	
RSD 1250/1800	08773	2	1800	1311	1460	12 x M 10	146	2	4	11	9	7	5	4	6	