

DV EC 400

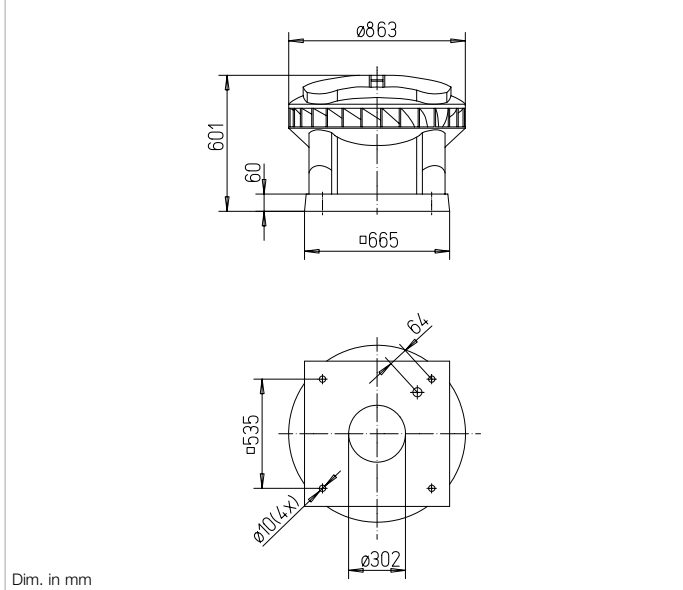

Dimensions DV EC 400



Dim. in mm

Extremely weather-resistant EC roof fan in plastic design for an extensive range of applications, diagonal outlet.

**Common features
 DV EC Pro and DV EC Eco**

- **Casing**
 Aerodynamically designed plastic casing made of grey polypropylene with diagonal air outlet direction. Air flow temperatures from -30 to +60 °C.
- **Impeller**
 Diagonal impeller made of aluminium, the motor impeller unit is dynamically balanced for low-noise operation.
- **Drive**
 Energy-efficient EC external rotor motor in protection category IP54. Optimised efficiency even with speed control for low operating costs. Continuously variable speed control. Maintenance-free and radio interference-free, ball bearing mounted.
- **Motor protection**
 Integrated electronic temperature monitoring system for EC motor and electronics.

- **Electrical connection**
 Standard operating switch (protection category IP65) mounted on the outside of the casing. Connection voltage 1~, 230 V, 50 Hz.
- **Installation**
 Horizontal alignment on the roof. In case of sloping roofs, a corresponding base formation must be used to prevent water ingress. A range of accessories facilitates the installation of the fan in the building duct system.
- **Noise**
 The total level and range are specified above the performance diagram for:
 Inlet side sound power
 Outlet side sound power.
 The case-radiated noise as sound pressure at 4 m (free field conditions) is also specified in the type table and the table below the performance curve.

PRO

**Description
 DV EC Pro**

- **Power control**
 - Ideal as a central exhaust air fan for multi-floor residential construction in accordance with DIN 18017-3.
 - When combined with other components (accessories), a complete central ventilation system in accordance with DIN 18017-3 can be created with demand-driven ventilation.
 - Integrated pressure control for constant volume flow control in the connected rooms through automatic speed adjustment at almost constantly high efficiency.
 - Integrated pressure sensor 0–300 Pa.
 - Short amortisation period due to high energy saving.
 - Operating data setting at the 4 potentiometers integrated in the control system to set the desired operating point on site.
 - Integrated serial bus interface (RS 485) for connection to a PC/laptop in connection with the interface (accessories).

ECO

**Description
 DV EC Eco**

- **Power control**
 - Continuously variable speed control with speed potentiometer PU/PA 10 (accessories, see type table).
 - When combined with the universal control system EUR EC or electronic pressure/temperature controllers EDR/ETR (accessories, see type table), the fan can be used for the continuously variable control of differential pressure, differential temperature or flow velocity. Performance levels are shown in the performance curve as an example.

Type	Ref. no.	Maximum speed approx.	Flow rate Free blowing	Noise sound press.	Power consumption at maximum speed		Wiring diagram	Max. air flow-temp.	Wgt net appr.	Universal control system		Speed potentiometer		Ref. no.		
					V	A				Type	Ref. no.	Type	Ref. no.	Type	Ref. no.	
		min ⁻¹	m ³ /h	dB(A) in 4 m	kW	A	No.	+ °C	kg	Type	Ref. no.	Type	Ref. no.	Type	Ref. no.	
PRO Type DV EC Pro, Single-phase alternating current, 230 V, 50/60 Hz, EC motor, IP54																
DV EC 400 A Pro	08387	1020	4070	51	0.30	1.33	863.1	60	33.0	–	–	–	–	–	–	
DV EC 400 B Pro	08389	1425	5650	65	0.75	3.32	863.1	60	35.0	–	–	–	–	–	–	
ECO Type DV EC Eco, Single-phase alternating current, 230 V, 50/60 Hz, EC motor, IP54																
DV EC 400 A Eco	08324	1020	4070	51	0.30	1.33	991	60	33.0	EUR EC ¹⁾²⁾	01347	PU 10 ³⁾	01734	PA 10 ³⁾	01735	
DV EC 400 B Eco	08326	1425	5650	65	0.75	3.32	991	60	35.0	EUR EC ¹⁾²⁾	01347	PU 10 ³⁾	01734	PA 10 ³⁾	01735	

1) Multiple EC fans can normally be connected.

2) Alternative elec. pressure/temp. controller (EDR/ETR, no. 01437/01438) in combination with mains adapter NG 24, no. 01439, see accessories.

Performance curves DV EC 400 A

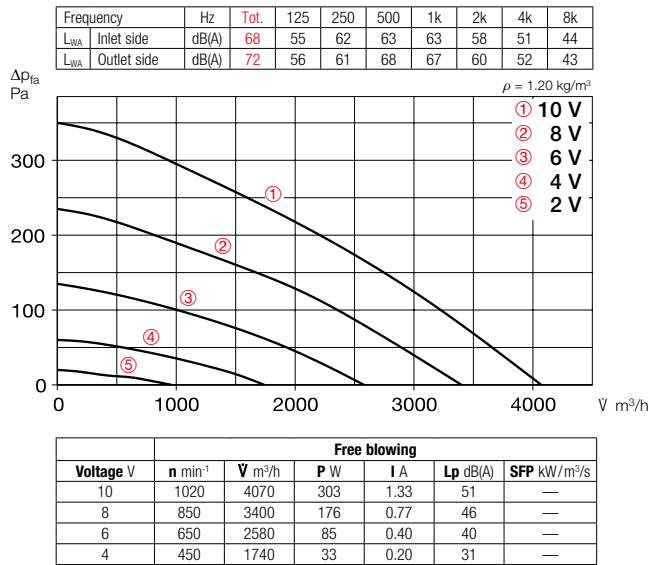

Performance curves DV EC 400 B

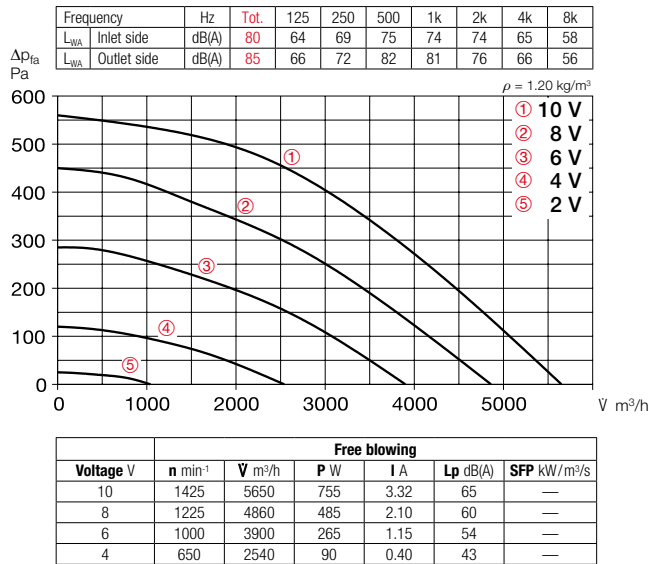

Accessory details	Page
Roof install. accessories	558 f.
Ventilation grilles	560 ff.
Exhaust air elements	574 ff.
Intake air elements	586 ff.
Fire protection systems	590 ff.
Universal control systems, electronic controllers, speed potentiometer	613 ff.

Accessories for all types

Base silencer
SSD 400 Ref. no. 05291
With hinge mechanism for easy inspection and cleaning.

Flange connection plate
FAP 400 Ref. no. 08384
Made of galvanised steel sheet. Allows the connection of the duct system and accessories to the roof fans DV EC if no base silencer SSD is used.

Flat roof base
FDS 400 Ref. no. 01380
With hinge mechanism for easy inspection and cleaning.

Counter flange
FR 400 Ref. no. 01206
Made of galvanised steel sheet, for inlet-side duct connection.

Flanged flexible connector
STS 400 Ref. no. 01223
For the prevention of structure-borne noise transmission to inlet-side ducts. Flanges made of galvanised steel sheet.

Duct shutter
RVS 400 Ref. no. 02596
Automatic, made of galvanised steel sheet, shutters made of aluminium. Prevents cold draughts when the fan is at a standstill. For vertical throughflow from bottom to top.

Accessories for DV EC Pro

Interface
ZLS-IF Ref. no. 08391
Interface for commissioning or controlling the fan in combination with a PC/Laptop via a USB port. The software can be downloaded and installed free of charge.

Electronic timer module
ZLS-ZU 31 Ref. no. 08388
Allows the parallel operation of max. 31 DV EC roof fans. The rocker switch is used to enable the DV EC fans. The day and night switchover takes place via the settings in the display. Incl. main switch. 230 V, 50 Hz.

Accessories for DV EC Eco

Universal control system
EUR EC Ref. no. 01347
For the continuously variable control or regulation of single and three-phase EC fans with a setpoint of 0–10 V DC.

Speed potentiometer
PU/PA 10 See type table
For the direct control/setpoint setting of EC fans with a potentiometer input.



EC roof fans

Timer for controlling max. 31 fans	
Type	Ref. no.
ZLS-ZU 31	08388
ZLS-ZU 31	08388
—	—
—	—

³⁾ W/o LED supply.