



Impeller
 High-performance centrifugal impeller with backward curved blades made of plastic (T120 and explosion-proof version made of aluminium). Dynamically balanced according to DIN ISO 21940-11 – quality grade 6.3.

Drive
 Speed-controllable external rotor motor in closed design (IP54) (explosion-proof version in IP44). Flange motor with self-ventilation (T120 version) in IP54. Ball bearing mounted with moisture protection. Maintenance-free and radio interference-free.

Motor protection
 Through built-in thermal contacts or built-in PTC thermistors, which must be connected to a motor protection circuit breaker. Assignment see type table.

Electrical connection
 No dismantling of casing, to external isolator switch (explosion-proof version to terminal box) in protection category IP65.

Protection grille
 On the outlet side as standard according to DIN EN ISO 13857.

Power control

All 1~ types have continuously variable speed control in the range from 0 – 100 % through electronic speed controllers or five-step control units. All 3~ types have continuously variable speed control in the range 0 – 100 % with a frequency inverter with integrated, all-pole effective sine filter (except for explosion-proof version) or five-step control units. Assignment see type table.

Delivery
 Units are ready-for-connection, fully pre-assembled in the shipping box.

Noise
 The total level and range are specified above the performance diagram for:

- Inlet side sound power
 - Outlet side sound power.
- The horizontally case-radiated noise as sound pressure at 4 m (free field conditions) is also specified in the type table. Hood silencer see Accessories.

References	Page
Planning information	14 ff.
Technical description	500 f.
Selection table	502 f.
Accessories, details	558 f.
Speed controllers, controllers and switches	599 ff.

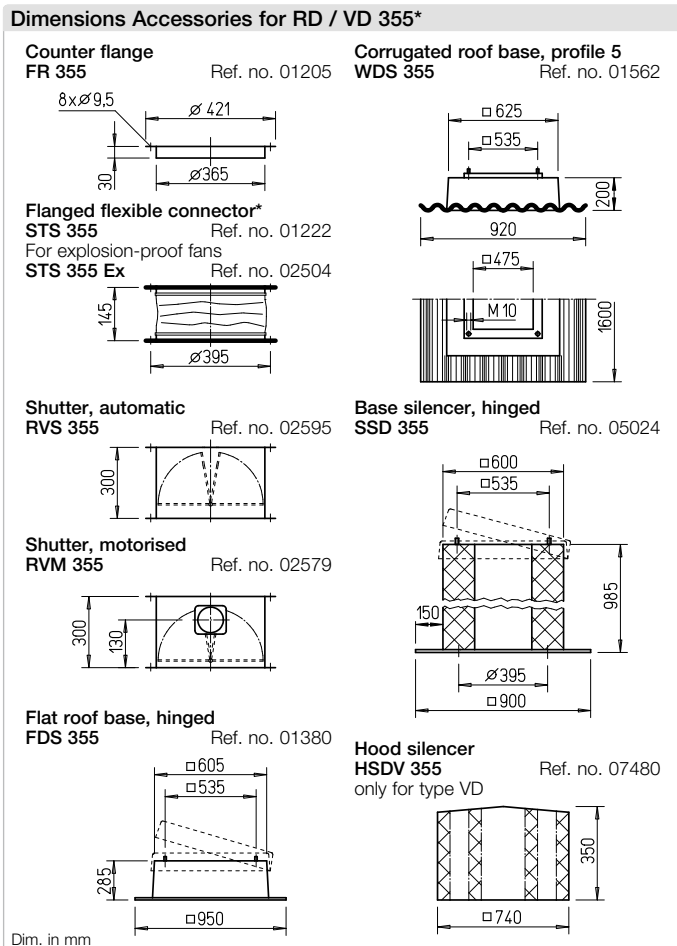
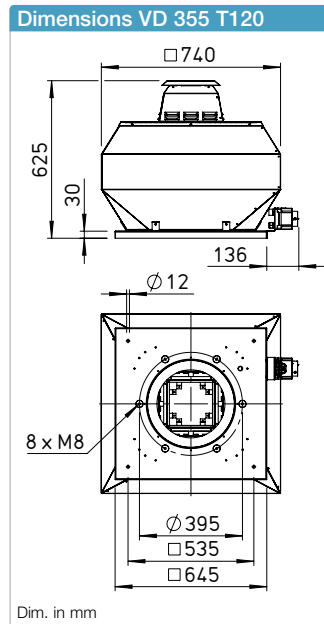
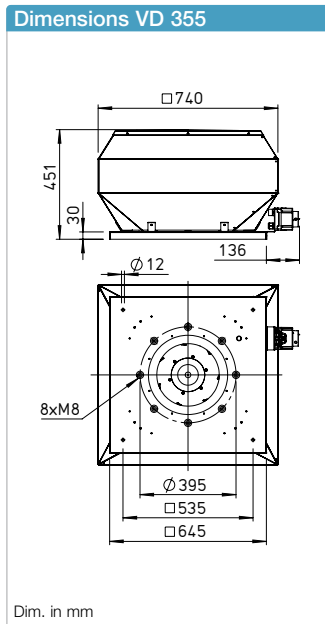
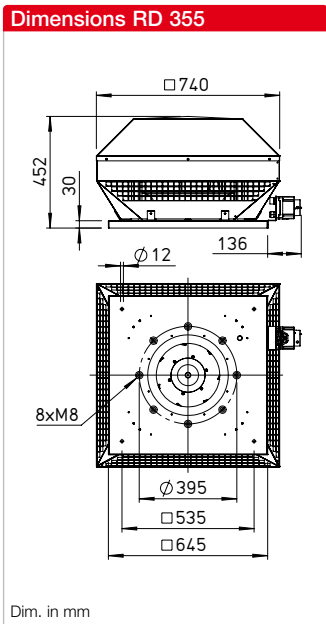

Description RD

Horizontal outlet roof fan with efficiency-optimised aluminium casing and newly developed high-performance centrifugal impeller.

Description VD

Vertical outlet roof fan with efficiency-optimised aluminium casing and newly developed high-performance centrifugal impeller.

Description VD T120

Designed for the delivery of process air up to +120 °C. Enclosed motor located outside of the air flow. Compliant with VDI 2052.

Description of all series

Casing
 Casing made of sea water-resistant aluminium with integrated tamper protection. Motor support plate and base plate with inlet nozzle made of galvanised steel (explosion-proof version inlet nozzle made of aluminium). Base plate with threaded screws for attachment of inlet-side accessories (hole pattern according to DIN 24155).

* Accessories VD T120 see installation accessories p. 559 f. Other accessories upon request.

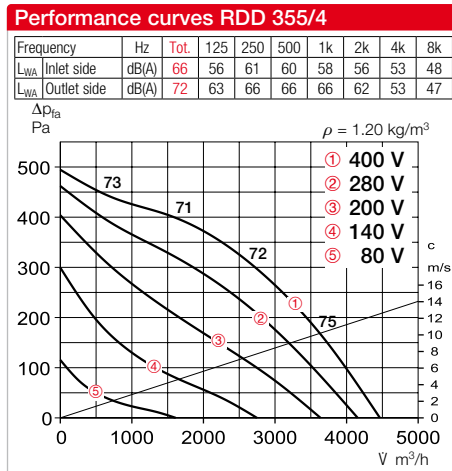
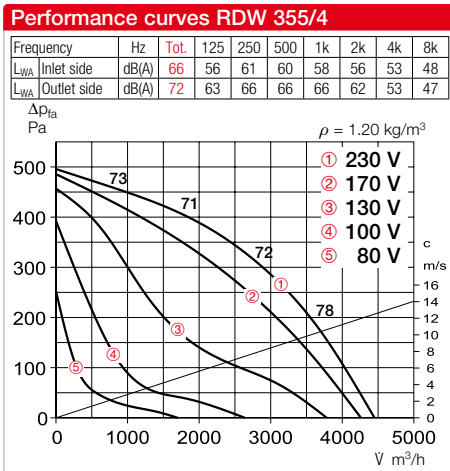

Type	Ref. no.	Speed	Flow rate Free blowing	Noise sound pressure	Power consump.	Current consump.		Wiring diagram	Max. air flow temp.		Weight net	Motor protection circuit breaker		Speed controller 5-step	
						at rated voltage	with control		at rated voltage	with control		Type	Ref. no.	Type	Ref. no.
		min ⁻¹	m ³ /h	dB(A) in 4 m	W	A	A	No.	°C	°C	kg	Type	Ref. no.	Type	Ref. no.
Single phase alternating current, 1~, 230 V, 50 Hz, Capacitor motor, protection category IP54															
RDW 355/4	07323	1400	4480	55	520	2.55	3.4	1128	70	55	27.0	MW	01579	MWS 5 ²⁾	01949
Three phase current, 3~, 400 V, 50 Hz, Squirrel-cage rotor, Protection category IP54															
RDD 355/4	07326	1350	4470	55	460	0.92	1.0	1129	60	60	25.0	MD	05849	RDS 2 ²⁾	01315
Ex Ex Explosion-proof, II 2G Ex h IIB + H₂ T3 Gb, Motor Ex e, Three phase current, 3~, 400 V, 50 Hz, Protection category IP44															
RDD 355/4 Ex ¹⁾	07329	1345	4345	58	540	1.21	1.21	1157	40	40	25.0	MSA	01289	TSD 3	01502

1) Performance diagram at www.HeliosSelect.de.

2) Includes motor protection circuit breaker.

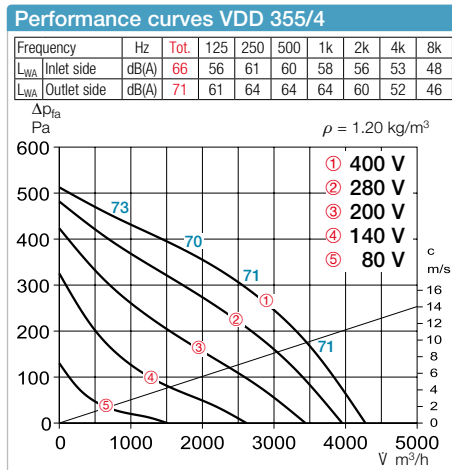
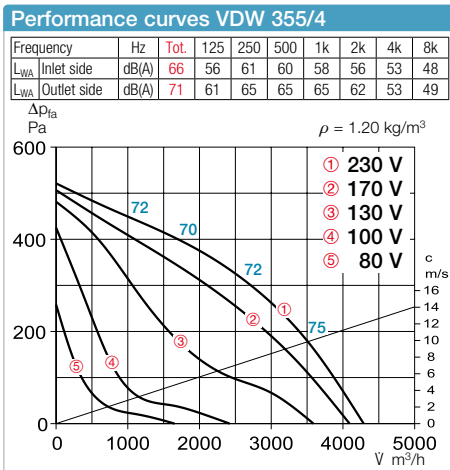

Type	Ref. no.	Speed	Flow rate Free blowing	Noise sound pressure	Power consump.	Current consump.		Wiring diagram	Max. air flow temp.		Weight net	Motor protection circuit breaker		Speed controller 5-step	
						at rated voltage	with control		at rated voltage	with control		Type	Ref. no.	Type	Ref. no.
		min ⁻¹	m ³ /h	dB(A) in 4 m	W	A	A	No.	°C	°C	kg	Type	Ref. no.	Type	Ref. no.
Single phase alternating current, 1~, 230 V, 50 Hz, Capacitor motor, protection category IP54															
VDW 355/4	07317	1400	4300	54	520	2.55	3.4	1128	60	55	27.0	MW	01579	MWS 5 ²⁾	01949
Three phase current, 3~, 400 V, 50 Hz, Squirrel-cage rotor, Protection category IP54															
VDD 355/4	07318	1350	4290	54	460	0.92	1.0	1129	60	60	25.5	MD	05849	RDS 2 ²⁾	01315
Ex Ex Explosion-proof, II 2G Ex h IIB + H₂ T3 Gb, Motor Ex e, Three phase current, 3~, 400 V, 50 Hz, Protection category IP44															
VDD 355/4 Ex ¹⁾	07327	1350	4320	57	520	1.17	1.17	1157	40	40	25.5	MSA	01289	TSD 3	01502
T120 Three phase current, 3~, 400 V, 50 Hz, Squirrel-cage rotor, Protection category IP54															
VDD 355/4 T120 ¹⁾	07336	1400	4597	58	584	1.3	1.4	1264	120	100	34.0	MD	05849	RDS 4 ²⁾	01316

1) Performance diagram at www.HeliosSelect.de.

2) Includes motor protection circuit breaker.