

**Description for all types**

■ **Casing**

Made of galvanised steel sheet, types HQ and HW have additional two layer lacquer coating in papyrus white.

■ **Impeller**

High performance characteristics with profiled blades made of plastic, aerodynamically optimised for application, dynamically balanced.

■ **Drive**

Energy-saving, speed-controllable external rotor EC motor in protection category IP54 with the highest level of efficiency. Maintenance-free and radio interference-free, excellent electromagnetic compatibility (EMC), ball bearing mounted.

■ **Motor protection**

Integrated electronic temperature monitoring system for EC motor and electronics.

■ **Electrical connection**

Standard terminal box (protection category IP54). Mounted to external cable for HQ and HW types (version "A") or on back of motor (version "B"). Mounted on outside of duct for HRF types.

■ **Protection grille**

Made of powder-coated steel for HQ and HW in accordance with DIN EN ISO 13857.

■ **Power control**

All types are continuously controllable via internal (delivery) or external speed potentiometer. Control is also possible via three level switch or continuously variable via universal control system or electronic differential pressure/temperature controller. See type table. Performance levels are shown on the performance curve as examples.

■ **Installation**

Installation possible in any position.

■ **Noise levels**

The total level and range for the sound power level and sound pressure level at 4 m free field conditions are specified above the performance diagram for the average operating point on the inlet/outlet side. The total sound pressure level at 4 m (free field conditions) is also specified in the type table, as well as the table below the performance diagram for various voltages. See page 14 f for noise emissions and room acoustics.

Speed	Flow rate-free-blowing	Power consump.	Current consump.	Sound pressure	Wiring diagram	Max. air flow temperature	Wgt net	Design type					
								HQ EC incl. protection grille	Ref. no.	HW EC incl. protection grille	Ref. no.	HRF EC	Ref. no.
min <sup>-1</sup>	V m <sup>3</sup> /h	kW	A	dB(A) at 4m	No.	+°C	ca. kg						
<b>Alternating current, 1~, 230 Volt, 50/60 Hz, EC motor, protection category IP54</b>													
1090	6320	0.29	1.30	54	1047	40	15.7	<b>HQW EC 500 A</b>	04934	<b>HWW EC 500 A</b>	04935	<b>HRFW EC 500 A</b>	04936
1450	8300	0.67	3.00	62	1201	40	17.7	<b>HQW EC 500 B</b>	04937	<b>HWW EC 500 B</b>	04938	<b>HRFW EC 500 B</b>	04939

### Performance curves HQ EC / HW EC / HRF EC 500 A

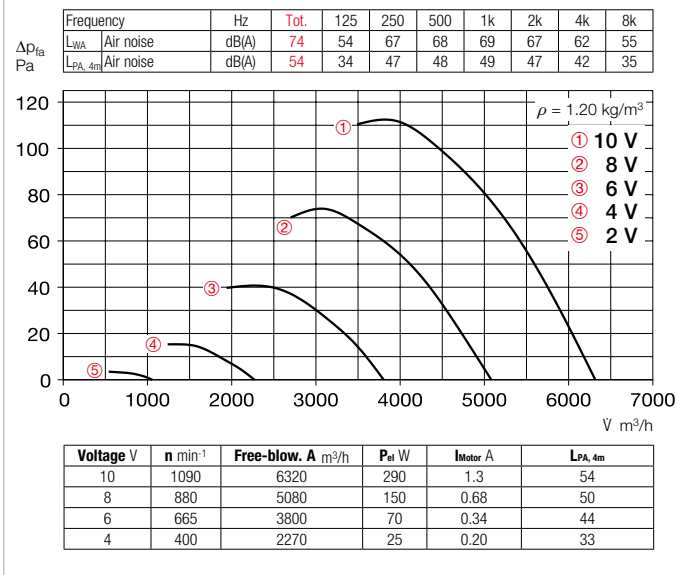

### Performance curves HQ EC / HW EC / HRF EC 500 B

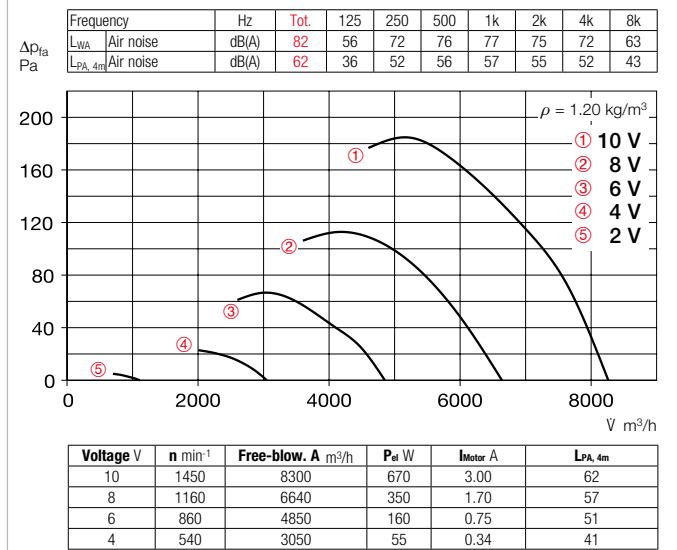

### Accessories for HRF EC 500 Description see page 280 ff.

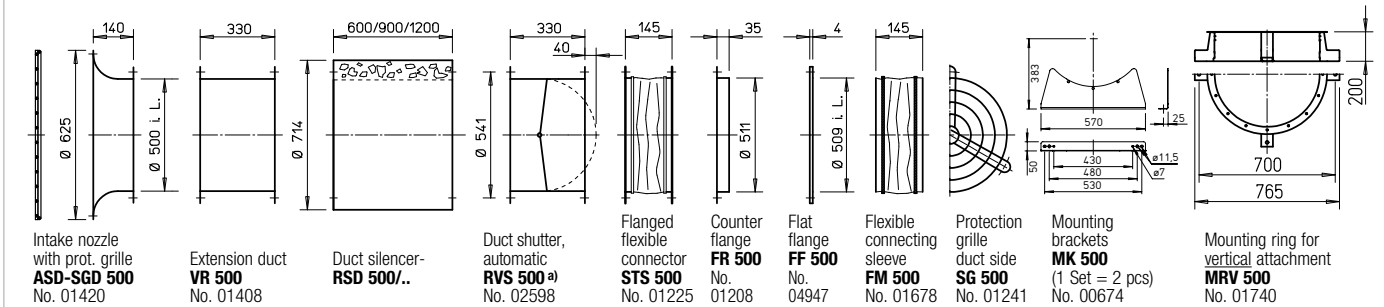

a) Shutter, motorised see Accessories product pages.

References	Page	Other accessories	Page
Techn. description	190	Filters and silencers	485 ff.
Selection table	191	Shutters and ventilation grilles	565 ff.
Planning information	14 ff.	Universal control system, electronic controller, Speed potentiometer	617 ff.
<b>Special design</b>		Five-step speed switch	620
Different voltage, air flow direction, higher air flow temperature, acid protection upon request.			
The technical information on p.19 ff. must be observed.			

Universal control system		Speed potentiometer		Three level speed switch		Electronic pressure difference controller/ actuator		Electronic temperature controller/actuator					
Type	Ref. no.	Type	Ref. no.	Type	Ref. no.	Type	Ref. no.	Type	Ref. no.				
EUR EC <sup>1)</sup>	01347	PU 10 <sup>1)</sup>	01734	PA 10 <sup>1)</sup>	01735	SU-3 10 <sup>1)</sup>	04266	SA-3 10 <sup>1)</sup>	04267	EDR <sup>1)</sup>	01437	ETR <sup>1)</sup>	01438
EUR EC <sup>1)</sup>	01347	PU 10 <sup>1)</sup>	01734	PA 10 <sup>1)</sup>	01735	SU-3 10 <sup>1)</sup>	04266	SA-3 10 <sup>1)</sup>	04267	EDR <sup>1)</sup>	01437	ETR <sup>1)</sup>	01438

1) Multiple EC fans can normally be connected, see Accessories.