

KWL EC 700 D

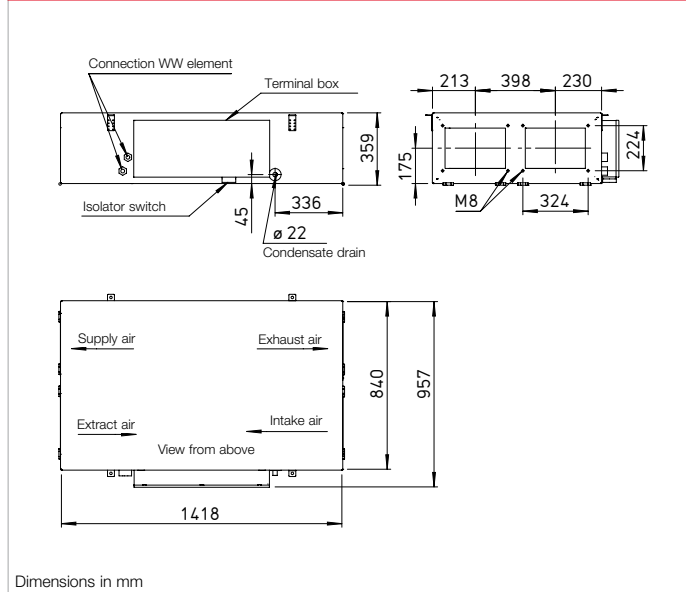

Dimensions KWL EC 700 D



Ultra-flat ventilation units with heat recovery for compact and space-saving ceiling installation.

With a wide range of residential, commercial and industrial applications. Independently certified hygiene properties and energy efficiency according to VDI 6022 and the passive house standard. Unit construction and unit components fulfil the general hygiene requirements according to VDI 6022.

Available in various comfort and equipment variants.

■ Casing

Double-walled, made of galvanised steel sheet, with 30 mm heat and sound insulation on all sides. The inspection openings for filter replacement are accessible at the bottom of the unit without tools.

Ceiling installation via vibration-damping fastening elements included in the delivery.

■ Heat exchanger

Large cross counterflow heat exchanger made of aluminium with heat recovery efficiency of up to 90 %. Dismantling possible in just a few simple steps.

■ Fans

Two low-noise high-performance EC fans with backward-curved impellers guarantee maximum energy efficiency. The special control technology enables constant volume control or constant pressure control.

■ Ducts

Installation-friendly connection of intake, exhaust, extract and supply air through pipe or duct system NW 250 mm.

■ Condensate connection

A separate condensate tray below the heat exchanger facilitates maintenance work on the unit. Drain connectors on the side next to the terminal box. Ball siphon included in delivery. On-site connection to drain pipe.

■ Air filter

Standard equipment: Clean intake air supply via ISO ePM₁ 55% filter (F7). The heat exchanger requires a ISO ePM₁₀ 50% filter (M5) on the extract air side. All filters are pressure-controlled and exchangeable in just a few simple steps.

■ Summer operation

Standard equipment with automatic bypass function for maximum comfort.

■ Heat exchanger anti-icing protection

An electric preheating element heats the intake air at very low outdoor temperatures. Thus, it prevents the heat exchanger from icing up and guarantees its safe functioning and optimal heat recovery during the entire heating period.

■ Power control

The comfort control element with graphic display and user-friendly menu navigation, which is included in the delivery, enables the following functions:

- Control directly via touchscreen.
- Freely definable operating points within the entire range of the performance curve.
- Selection between constant volume control or constant pressure control.
- Demand-oriented ventilation using CO₂, VOC (mixed gas) or humidity sensor.
- Initial commissioning (automatic determination of the system performance curve).
- Control of external shutters.
- Connection of a fire alarm contact.
- Weekly or daily programme.
- Pressure monitoring of filter contamination.
- Indication of necessary filter replacement, operating status, error messages.
- Different access levels. The ventilation unit is alternatively controllable via ModBus (RS 485, TCP/IP).

■ Electrical connection

Easily accessible terminal box on the side of the casing. The isolator/main switch can be controlled from below the unit for maintenance work and it can be locked with a padlock to prevent unauthorised access.

■ Post-heating

Type KWL EC Pro WW

The integrated warm water heating element guarantees the convenient and energy-efficient post-heating of supply air. The setpoint temperature is simply set in the control element. The hydraulic unit (Type WHSH HE 24 V (0-10 V), accessories) is recommended for controlling the warm water heat exchanger.

■ Reference

The ventilation unit design according to VDI 6022 requires the use of VDI 6022-compliant air filters. The use of original replacement air filters is therefore mandatory.

■ Replacement air filter

- 1 pc. ISO ePM₁₀ 50% (M5) ELF-KWL 700 D/5 VDI No.04189
- 1 pc. ISO ePM₁ 55% (F7) ELF-KWL 700 D/7 VDI No.04191

■ Control lines

- ALB EC-SK 20 20m** No. 06816
 - ALB EC-SK 40 40m** No. 06817
- 8-pin AWG24 twisted pair cable for the control element.

■ Other accessories Page

KWL peripherals	150 ff.
– Air distribution systems	166 ff.
– Further overview	170 f.

Accessory details

Ventilation grilles, ducts, fittings	
roof outlets	561 ff.
extract air elements	574 ff.

Performance curve KWL EC 700 D

Frequency	Hz	Tot.	125	250	500	1k	2k	4k	8k
L _{WA} Extract air	dB(A)	53	46	49	47	41	40	34	23
L _{WA} Supply air	dB(A)	68	54	65	63	59	53	48	39
L _{PA} at 1 m	Radiation	47	33	41	43	41	35	29	14

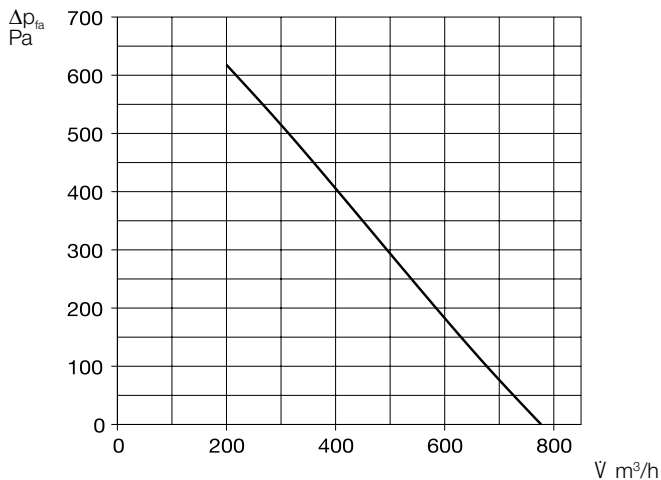

Included in delivery:

Surface comfort control element

User-friendly control via self-explanatory graphic elements with clear text directly on the touchscreen. Control line (10 metres) included in delivery, other lengths available (ALB EC-SK, accessories).
Dim. mm (WxHxD) 115x80x25



Control element with connection cable (10 m) included in the scope of delivery. Dim. mm (WxHxD) 115 x 80 x 25

Accessories for Type Pro WW

Hydraulic unit

WHSH HE 24 V (0-10 V) No. 08318

Controls the water temperature of the PWW heating element using a three-way valve actuator 24 V (0-10 V) and thus the heat output transferred to the air. Delivered as a complete unit, incl. VL-/RL temperature display, circulating pump and flexible connection hoses.



Accessories for all types

Room sensor – Air quality

AIR1/KWL-VOC 0-10V No. 20250

AIR1/KWL-CO2 0-10V No. 20251

AIR1/KWL-FTF 0-10V No. 20252

For measuring the CO₂, mixed gas (VOC) concentration or relative room air humidity. A maximum of one sensor can be connected.
Dim. mm (W x H x D) 85 x 85 x 27



Room sensor – Temperature

TFR-ALB/KWL No. 07277

For measuring the room temperature and controlling the ventilation unit according to the set value. Incl. 20 m control line. Maximum total of one sensor can be connected.
Dim. mm (W x H x D) 80 x 80 x 25



Transition piece – Symmetrical

KWL-ÜS 700 D No. 04206

From unit flange to round duct systems.

Flexible connecting sleeve

FM 250 No. 01672

For acoustic decoupling, incl. 2 pcs. hose clamps.

Duct shutter, motorised

RVMD 250/230V No. 40252

Prevents cold draughts when the unit is at a standstill. Can be installed horizontally and vertically in any direction and with attached spring return motor (outside of air flow).

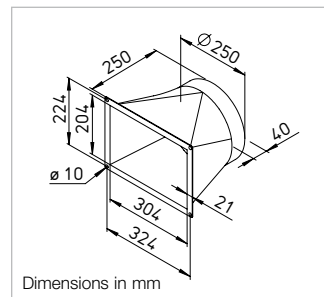

Dimensions in mm



Technical data	KWL EC 700 D			KWL EC 700 D, with warm water post-heater		
For ceiling installation	Type KWL EC 700 D Pro	Ref. no. 04171	Type KWL EC 700 D Pro WW	Ref. no. 04172		
Flow rate at level¹⁾ Supply air/extract air V m ³ /h approx.	③ 510	② 330	① 210	③ 510	② 330	① 210
Noise dB(A)²⁾						
Supply air L _{WA} (sound power)	69	64	61	70	65	61
Extract air L _{WA} (sound power)	58	52	48	58	52	48
Radiation L _{PA} at 1 m	37	32	30	38	33	30
Power consumption fans 2 x W	110	60	38	110	60	38
Voltage/Frequency	230 V~, 50 Hz			230 V~, 50 Hz		
Rated current A – Ventilation	2.3			2.3		
– Preheating	12.0			12.0		
– max. total	14.3			14.3		
Heat output/Postheater kW	–			2.3 (at 60/40 °C) / 2.1 (at 50/40 °C) / 1.3 (at 40/30 °C)		
Electric preheater kW	–			2.6		
Summer bypass	–			automatic		
Wiring diagram no.	1370			1370		
Temperature operating range	–20 °C to +40 °C			–20 °C to +40 °C		
Connection PWW heating element	–			IG 1/2"		
Weight approx. kg	110			115		

¹⁾ Values based on operating ranges defined according to PHI (Passive House Institute).

²⁾ At 100 Pa.