

**IVAD 315**

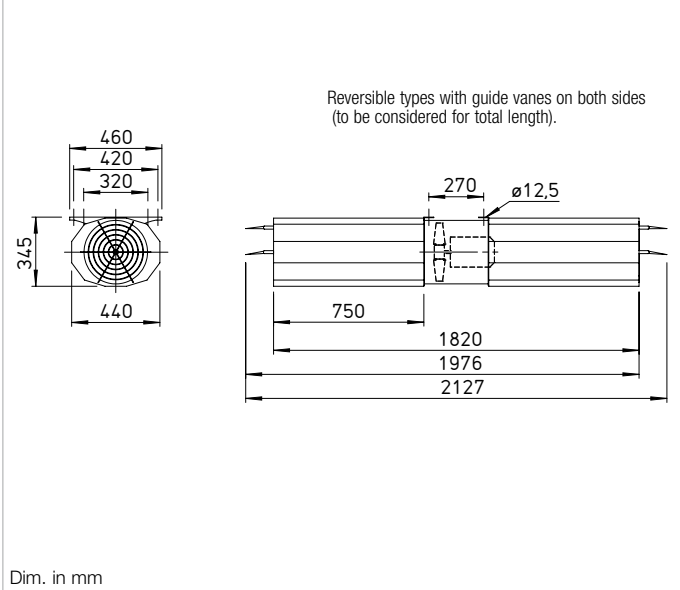

**Dimensions IVAD 315**



**High-quality, high-performance jet fans with optimal dimensions for minimum space requirement. Suitable for supply and extract ventilation of car parks with air flow temperatures up to 60 °C.**

**Special features**

- Low noise emission.
- Maximum thrust.
- Easy and fast to install due to low weight (aluminium construction).
- Direct driven, axial.
- Optional 100% reversible (types IVAD R).

**Casing**

Duct casing made from corrosion-resistant aluminium with motor support and ceiling suspension. Aerodynamically shaped inlet with guard, outlet nozzle with adjustable guide vane. Reversible types with adjustable guide vanes (to be considered for total length).

**Impeller**

High-performance impeller for unidirectional and reversible operation. Dynamically balanced, quality class 6.3. With flow-optimised blades made from corrosion-resistant aluminium alloy, adjustable in standstill.

**Motor**

Direct via efficient IE 3 three phase motor. Pole-switching fans with IEC standard motor. Protection class IP55.

**Motor protection**

All types are equipped with PTC resistors from the terminal boxes. Thus, efficient motor protection is possible by means of full motor protection device (type MSA, Ref. no. 01289, Accessories) or FU (Accessories).

**Noise insulation**

Polygon attenuators mounted on both sides, whose aluminium casings are fully lined with abrasion-resistant mineral wool and galvanised perforated plate according to DIN 4102 (non-flammable).

**Installation**

With integrated mounting rails as standard, which are fixed directly to the ceiling using plugs (Accessories, on-site) at four fixing points.

In order to prevent vibration transmission, the use of anti-vibration mounts is recommended (SDZ, Accessories, see table).

**Electrical connection**

Plastic terminal box (protection class IP55) as standard, outside on casing.

**Assembly**

The Federal, State and regional regulations and ordinances must be observed for the assembly.

**Accessories**

**Anti-vibration mounts for tensile loading (1 set = 4 pcs.)**



Information	Page
Techn. description	144 f.
Accessory details	Page
Anti-vibration mounts	165
Gas warning systems	170 f.

Type	Ref. no.	Thrust	Discharge speed	Max. output	Nominal speed	Reversible	Sound pressure level <sup>1)</sup>	Nominal motor power (output)	Nominal motor current		Wiring diagram	Max. air flow temperature	Net weight approx.	Anti-vibration mount (1 set = 4 pcs.)	
									Operation	Start-up				Type	Ref. no.
<b>60° Three phase motor, 400 V, 50 Hz, protection class IP55</b>															
IVAD 315/2 R	04102	23	15.4	4400	2890	Yes	59	1.10	2.3	8.0	796	60	37	SDZ 1	01454
IVAD 315/2	04110	25	15.9	4600	2890	No	58	1.10	2.3	8.0	796	60	37	SDZ 1	01454
<b>60° Pole-switching, 2 speed, three phase motor, Dahlander winding <math>\Delta/\Delta</math>, 400 V, 50 Hz, protection class IP55</b>															
IVAD 315/4/2 R	04101	6/23	7.6/15.3	2200/4400	1340/2835	Yes	39/59	0.25/0.95	0.9/2.3	4.6/17.2	777	60	42	SDZ 1	01454
IVAD 315/4/2	04109	6/24	7.9/15.8	2200/4400	1340/2835	No	39/58	0.25/0.95	0.9/2.3	5.0/17.4	777	60	42	SDZ 1	01454

<sup>1)</sup> measured in freefield conditions below 45°, at distance of 3 m