

B IVRD 560 F300

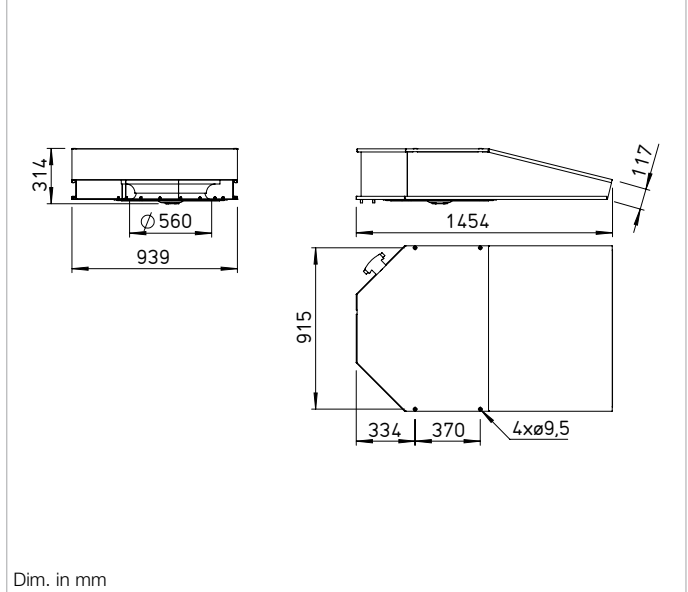

Dimensions B IVRD 560 F300



High-quality, high-performance jet fans with optimal dimensions for minimum space requirement. Suitable for supply and extract ventilation of car parks. Temperature range 300 °C/120 min. (in smoke extraction operation) or 60 °C in permanent operation.

Special features

- Low noise emission.
- Maximum thrust.
- Easy and fast to install due to low weight (aluminium construction).
- Direct driven, centrifugal.

Casing

Casing made from corrosion-resistant aluminium in compact design. Aerodynamically shaped inlet nozzle. Permanent optimal surface protection through steel powder coating.

Impeller

High-performance centrifugal impeller with welded, backward curved blades. Dynamically balanced, quality class 6.3.

Motor

IEC three phase standard motor in temperature-resistant design, protection class IP55.

Motor protection

All types are equipped with PTC resistors from the terminal boxes. Thus, efficient motor protection is possible by means of full motor protection device (type MSA, Ref. no. 01289, Accessories) or FU (Accessories). For the smoke extraction function, all full motor protection devices and speed controllers (FU) for the smoke extraction fan must be bridged to achieve the required output and max. operating duration.

Installation

With integrated mounting brackets as standard, which are fixed directly to the ceiling using plugs (Accessories, on-site) at four fixing points. In order to prevent vibration transmission, the use of anti-vibration mounts is recommended (SDZ, Accessories, see table).

Electrical connection

Aluminium die-cast terminal box (protection class IP55) as standard, outside on casing. On-site cabling with temperature-resistant connection cable.

Assembly

The Federal, State and regional regulations and ordinances must be observed for the assembly.

Certification

- Structural tolerances according to DIN 2768
 - Performance measurement according to DIN 24163
 - The jet fans B IVRD have been tested according to DIN EN 12101-3.
- EC certificate of compliance: F300: 0036-CPR-RG05-17

Accessories

Anti-vibration mounts for tensile loading (1 set = 4 pcs.)

SDZ 1 F



Information	Page
Techn. description	144 f.
Accessory details	Page
Anti-vibration mounts	165
Gas warning systems	170 f.

Type	Ref. no.	Thrust	Discharge speed	Max. output	Nominal speed	Sound pressure level ¹⁾	Nominal motor power (output)	Nominal motor current		Wiring diagram	Max. air flow temperature ²⁾	Net weight approx.	Anti-vibration mount (1 set = 4 pcs.)	
								Operation	Start-up				Type	Ref. no.
F300 Three phase motor, 400 V, 50 Hz, protection class IP55		N	m/s	V m ³ /h	min ⁻¹	dB(A)	kW	A	A	No.	+ °C	kg		
B IVRD 560/4 F300	04159	75	25.2	8900	1410	77	2.20	5.2	34.0	776	60/300	70	SDZ 1 F	01943
F300 Pole-switching, 2 speed, three phase motor, Dahlander winding $\gamma/\gamma\gamma$, 400 V, 50 Hz, protection class IP55														
B IVRD 560/8/4 F300	04160	19/75	25.2/12.5	4500/8900	700/1420	77/58	0.50/2.20	2.0/5.0	7.1/30.7	777	60/300	72	SDZ 1 F	01943

¹⁾ measured in freefield conditions below 45°, at distance of 3 m

²⁾ For ventilation / smoke extraction (one-off 120 min.)