

B VD 710 F400/F600

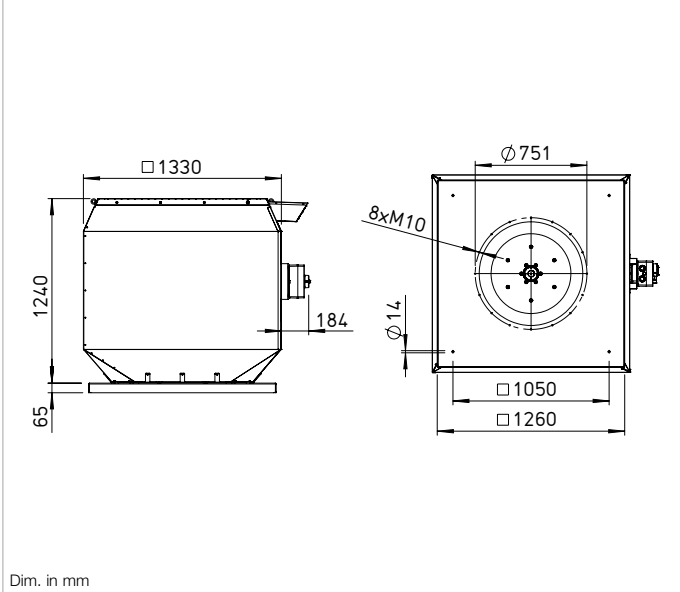

Dimensions B VD 710 F400/F600



Dim. in mm

Application

- In mechanical smoke extraction systems (MRA) for ensuring smoke extraction in special structures, such as sales locations, large garages, meeting locations or industrial buildings.
- Smoke extraction with temperature classes F400 and F600.
- Also suitable for ventilation operation (Dual-Use).
- For increased ventilation requirements with a continuous air flow temperature of up to 120 °C.

Features

- Smoke exhaust roof fan as a smoke extraction fan with dual-function (smoke extraction and ventilation).
- Robust design with efficiency-optimised casing for difficult operating conditions.
- High operational reliability due to minimal maintenance requirements.
- Ready-for-use delivery for easy installation.
- Base plate with threaded bolts for the easy mounting of inlet-side accessories.
- Standard PTC thermistor as motor protection for ventilation operation (motor protection devices must be automatically deactivated in case of fire for max. operating duration).

- Motor outside of air flow, enclosed in self-ventilated motor casing for optimal motor cooling.
- Comprehensive accessories enable perfect compliance with property-specific requirements.
- Isolator switch for electrical connection as standard.
- Perfectly tuned for operation with frequency inverter.

Casing

- Made of seawater-resistant aluminium for maximum weather protection.
- Base plate with inlet nozzle and motor support made of hot-dip galvanised steel sheet.
- Vertical air outlet prevents damage to adjacent parts of the building in case of fire.
- Outlet-side aluminium protection grille.
- Standard transport lugs for simple positioning.
- Attractive architectural design.

Impeller

- Directly driven high-performance centrifugal impeller, with eight backward curved blades.
- Design made of powder-coated steel sheet.
- Single-side inlet.
- Dynamically balanced, quality class 6.3.

- High efficiency for maximum output with low-noise operation.
- Direct mounting of hub to motor shaft.

Drive

- High-quality smoke exhaust motor for high environmental temperatures, perfectly tuned for use in smoke extraction fans.
- Enclosed motor design, protection category IP55.
- Winding in insulation class H.
- Motor outside of air flow, protected from this by thermal separation.
- Innovative motor cooling concept, perfectly tuned for smoke extraction with frequency inverter operation and reduced speed.
- Motor cooling airflow through intake duct. Automatic flow during fan operation.
- Motor bearings can be monitored with Helios bearing condition diagnostics system (Accessories).

Speed control

- Optimal ventilation operation with speed control by means of frequency inverter.
- Smoke extraction possible with frequency inverter operation, elaborate bypass circuit can be omitted in case of fire.

- It must be ensured that operation takes place at the speed required for the smoke extraction flow rate for smoke extraction.
- Frequency inverter with all-pole sine filter and special operating mode for smoke ventilation operation is essential (Accessories).

Dual function (Dual-use)

- Approved for daily ventilation on demand and smoke extraction.
- Ventilation in continuous operation possible.
- High efficiency meets the ERP requirements for Dual-Use smoke extraction fans.

Assembly/Installation

- Outdoors on horizontal roof (vertical motor shaft) or flat roof base. Flat roof base, see Accessories.
- Snow load class 0 pursuant to DIN EN 12101-3, installation on roofs above heated rooms. For snow load class SL 2000 und SL 3000: Outlet-side deflector, see Accessories.
- Standard transport lug for simple positioning.
- Inlet-side connectable accessories can be attached to the threaded bolts in the base plate (hole pattern according to DIN 24155).

Type	Ref. no.	Speed	Output free-blowing	Sound pres. casing-radiated	Sound power level casing-radiated	Nominal motor output	Nominal motor current	Starting current	Wiring diagram	Net weight approx.	Frequency inverter		Smoke ventilation fan control system	
											Type	Ref. no.	Type	Ref. no.
F400 Single speed, three phase motor 400 V, 50 Hz, protection category IP55														
B VDD 710/4 F400	01646	1.465	34.850	80	100	15.00	27.90	201	1307	403	FU-CS 32	05471	EVS-SD 005	04582
B VDD 710/6 F400	01647	965	22.950	76	96	4.00	9.11	55.6	1261	338	FU-CS 10	05874	EVS-SD 001	04586
F600 Single speed, three phase motor 400 V, 50 Hz, protection category IP55														
B VDD 710/4 F600	01648	1.465	34.850	80	100	15.00	27.90	201	1307	403	FU-CS 32	05471	EVS-SD 005	04582
B VDD 710/6 F600	01698	965	22.950	76	96	4.00	9.11	55.6	1261	338	FU-CS 10	05874	EVS-SD 001	04586

Performance diagram B VD 710 F400/F600

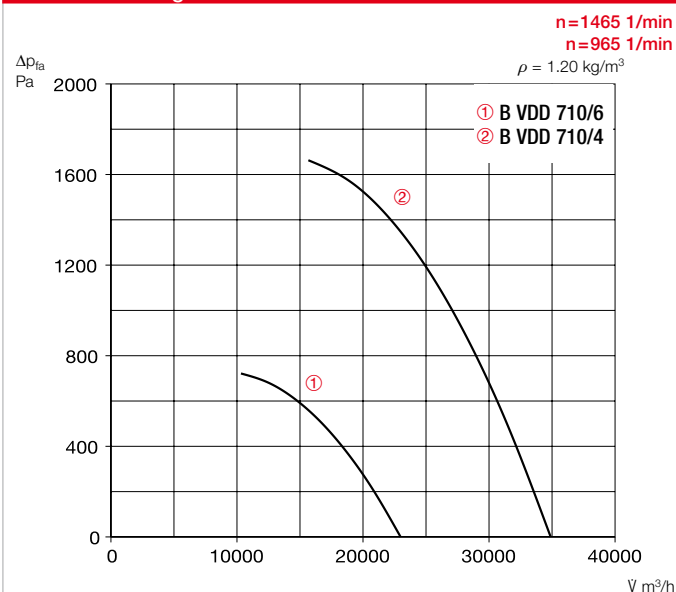

Air flow temperature

- Temperature classes F400 and F600.
- Smoke extraction 400 °C/120 minutes, or 600 °C/120 minutes.
- 120 °C continuous air flow temperature.
- For ambient temperatures from -20 °C to +60 °C.

Noise levels

- The horizontally radiated noise is specified as sound pressure level in 4 m (freefield conditions) in the type table.
- Different installation situations or disturbed flows can lead to increased noise levels.
- Hood silencer and silencer insert for flat roof base, see Accessories.

Motor protection

- All types have PTC thermistors in the motor winding as standard.
- PTC thermistor assessment with suitable full motor protection device, EVS or frequency inverter (Accessories).
- The motor protection must be automatically bridged/bypassed in case of smoke extraction (deactivation) to ensure the maximum function duration.

Voltages and frequencies

- Nominal voltage and frequency are specified in the table. These also form the basis for the performance data.

Electrical connection

- To external isolator switch in protection category IP65.
- Isolator switch can be locked in position "0 OFF" and "I ON" using on-site padlock.
- Fans with a nominal motor output up to 2.20 kW can be directly activated, with star-delta start-up for 3.00 kW and above.

Delivery information

- Ready-to-use units, completely pre-assembled.
- Simple positioning with standard transport lug.

Safety information

- Outlet-side with aluminium protection grille as standard. Prevents penetration of leaves and solids and provides contact protection.

Fire test

- Successfully tested according to DIN EN 12101-3: 2015-12.

Certification

The smoke extraction fans BK have been tested according to DIN EN 12101-3. Certificate of performance reliability:
F400: 0761-CPR-1052
F600: 0761-CPR-1053

Accessories

Flat roof base

B FDS 710/300 Ref. no. 01868
B FDS 710/500 Ref. no. 01869
Flat roof base for B VD F400 and F600 in heights 300 mm and 500 mm for mounting on flat roof.

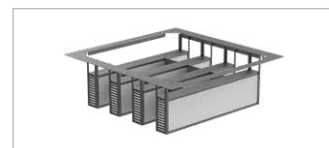

Silencer insert

B SSD 710 Ref. no. 03523
Silencer insert with connectors for flat roof base for inlet-side noise reduction. Flat roof base B FDS required.



Hood silencer

B HSDV 710 Ref. no. 03253
Hood silencer with inner core for outlet-side noise reduction.



Deflector

B DEF 710/2000 Ref. no. 40084
B DEF 710/3000 Ref. no. 03468
Deflector with snow load class SL 2000 and SL 3000 for mounting on B VD F400 and F600.

Inlet nozzle with protection grille

ASD-SGD 710 Ref. no. 01423



Flexible connector

STSB 710 F400 Ref. no. 01918
STSB 710 F600 Ref. no. 02006



Extension duct

VR 710 Ref. no. 01411

Duct shutter

RVS 710 Ref. no. 02601

Smoke exhaust fan control system

EVS-SD 005 (15,0 kW) no. 04582
EVS-SD 001 (4,0 kW) no. 04586
Smoke exhaust fan control system for the operation of B VD F400/F600.



Bearing condition diagnostics system

LZD-Basic Ref. no. 27495
LZD-Comfort Ref. no. 27497
For ensuring the functionality of motor bearings. Factory-mounted to fan.

Information
Notes on operation in case of fire:
– Unhindered discharge of smoke gases at all times.
– Motor protection devices must be automatically bridged.
– Secure electrical power supply (safety power supply) required.
The relevant regulations apply for the maintaining the functionality of electrical circuit systems.
Planning information p. 13 ff.

Accessories	Page
Mounting accessories	161 ff.
Control devices, switches	168 ff.