

## LS / LS EC and B LS



Also available  
in version:



### Garage ventilation control system

The Helios garage ventilation control system was specially developed to meet the requirements for modern and efficient ventilation of garages. The use of Helios fans and the ventilation control system LS significantly reduces the risks to people from toxic gases such as carbon monoxide (CO) and nitrogen dioxide (NO<sub>2</sub>).

- Two fans are operated and monitored by the ventilation control system LS according to the provisions of the Ordinance Governing Parking Facilities. Pollutants resulting from garage use are diluted and discharged through the air exchange stipulated in the respectively valid Ordinance Governing Parking Facilities (GaVO).
- The LS monitors the control circuit and load circuit, detects faults or power failures and switches over to the system that is still functional.
- In addition to the automatic mode, the fans also can be operated individually, together or alternately to achieve the same fan running times.
- If only one fan is operating, the garage ventilation control system LS is programmed in such a way that the second fan automatically goes into operation and a fault signal is transmitted in case of such a failure.

### Delivery range

Vent. contr. system	with smoke extr. function	Switch	Current	Voltage	Performance range
LS-W / LS-W EC	B LS-W	Direct / EC	1~	230 V	Up to 4,0 kW
LS-D / LS-D EC	B LS-D	Direct / EC	3~	400 V	Up to 2,2 kW / EC up to 4 kW
LS-SD	B LS-SD	Y/Δ	3~	400 V	From 3,0 kW to 18,5 kW
LS-DA	B LS-DA	Y/Y	3~	400 V	Up to 18,5 kW
SSTG	SSTG	Individual	3~	400 V	Individual

Types with greater performance upon request.

### Delivery range

The Helios range of garage ventilation control systems includes 1~ and 3~ models in various performance ranges for direct and star-delta start-up and with Dahlander winding or EC motors for fan operation at two different speed pursuant to the table below. All models are optionally available with additional smoke ventilation function (types B LS) (except EC).

### Order information

When ordering the garage ventilation control system, the following specifications are required:

- **Required control system type**  
Garage ventilation control system (LS) or Garage ventilation control system with additional smoke extraction function (B LS).
- **Fan types**  
The performance range, switching type and motor protection device of the garage ventilation control system can be found in the type specification of the fan to be controlled (Helios reference number).

### Casing

The system is delivered ready-for-use and easy to install and service in a plastic casing (types up to 4 kW) or in robust switch cabinet casing made from sheet metal (types from 4 kW).

### Operation

The operating mode and fan sequence can be set using the rotary switch on the control panel. The running times of the connected fans can be individually programmed using the analogue timer.

	Position	Function
□ Fan sequence	"1"	Fan 1 activated for operation. Switch to fan 2 in case of fault.
	"2"	Fan 2 activated for operation. Switch to fan 1 in case of fault.
	"1+2"	Both fans successively activated for operation.
	"1/2"	Both fans alternatively activated for operation to achieve the same running times.
□ Oper. mode	"Auto"	Pre-selected fan sequence controlled by timer.
	"Manual"	Fan operation controlled by manual adjustment on "Fan sequence" rotary switch.
	"Off/unlock"	The control system is deactivated. Faults are deleted.
□ Timer		The analogue timer allows the individual adjustment of fan running times to the respective situation in the garage to be ventilated. "Auto" mode must be selected on the garage ventilation control system for the corresponding controlling of programmed times. The shortest timer switching sequence is 20 minutes.

### Display function

The status of the connected fans and the position of the supply/extract air shutters are indicated separately place for each fan via LEDs. Fault signals and triggered fire dampers are also indicated by LEDs on the control system in addition to the acoustic warning via the optionally connectable siren.

	Operation	Function
□ Damper OPEN	Green LED lights up	Supply or extract air damper is opened, fan runs 30 seconds delayed.
	Green LED goes off	Supply or extract air damper is closed, fan is off.
□ Fan ON	Green LED lights up	Fan is in operation, associated supply or extract air damper is opened.
	Green LED goes off	Fan is not in operation, associated supply and extract air damper is closed.
□ Fault	Red LED flashes	Fan fault.
□ Fire damper	Red LED lights up	Fire damper triggered.

### Garage ventilation control system with smoke extraction function B LS

If there are garage smoke extraction requirements in case of fire in addition to the ventilation and the associated reduction of the pollutant concentration, the garage ventilation control system B LS with smoke extraction function is the optimal solution.

- By connecting the smoke exhaust garage ventilation control system B LS to a smoke detector line or a fire alarm system, the smoke extraction function is automatically triggered in case of fire. One or more push-button alarms and a fire service switch can be attached for manual triggering by garage users and the fire service.
- Once the smoke extraction function is triggered, all motor protection devices are bridged and

the smoke exhaust fans will run at nominal speed. Stage 2 (maximum fan speed) is automatically set for control systems with Dahlander windings.

- The operation of F600 smoke exhaust fans with cooling air fans is not possible when using the Helios smoke exhaust garage ventilation control system.

### Technical data

Timer	24 h
Switching sequence	20 min.
Switching capacity	Damper 500 VA Siren 500 VA
Switching current	Damper max. 2 A Siren max. 2 A
Control fuse	12 V 0,5 A 230 V 2 A
Ambient temperature	0 to +40 °C
Protection category	IP54
Installation position	Vertical

## Individual system solution Type SSTG

- Garage switch cabinet specifically adapted to the building project with power units for all supply air fans, extract air fans and jet fans to be controlled.
- Control via respective load contactors or with frequency inverter or for EC fans.
- With additional smoke extraction function, also available for multiple fire sections, for controlling Helios smoke exhaust fans and any smoke extraction dampers.
- In case of fire, the motor protection devices for the smoke extraction fans are automatically bridged pursuant to VDMA 24177, to ensure the smoke extraction function until the destruction of the fan.
- The Helios gas warning system controller and the corresponding USV can be integrated in the system. The display and operating panel is then integrated in the switch cabinet door.

## Information

- In accordance with applicable garage regulations and VDI directives, the ventilation system requires two fans, each of which must provide at least 50 % of the total air flow volume. In case of the failure of one fan, the other fan must be able to provide 2/3 of the total air flow volume.
- The garage fans must be wired to their own electrical circuits to which no other electrical systems can be connected.

## Operating and display panel

The functionality and operation of the Helios garage ventilation control system can be adjusted on the clearly arranged control and display panel. The front panel is well protected by a lockable cover against access by unauthorised persons.

## Line monitoring B LS

The detector circuits for the fire alarm system, as well as the smoke detector, push-button alarm and fire service switch are monitored for wire breakage and short circuit. The detector circuits are executed in limit value technology.

## Motor protection

- The motors of the connected fans are protected by deactivation in case of overload by the garage ventilation control system LS. For motors with thermal contacts or PTC thermistors, this can be connected to the garage ventilation control system terminal block. For motors without thermal contacts or PTC thermistors, the garage ventila-

System diagram B LS with smoke extraction function

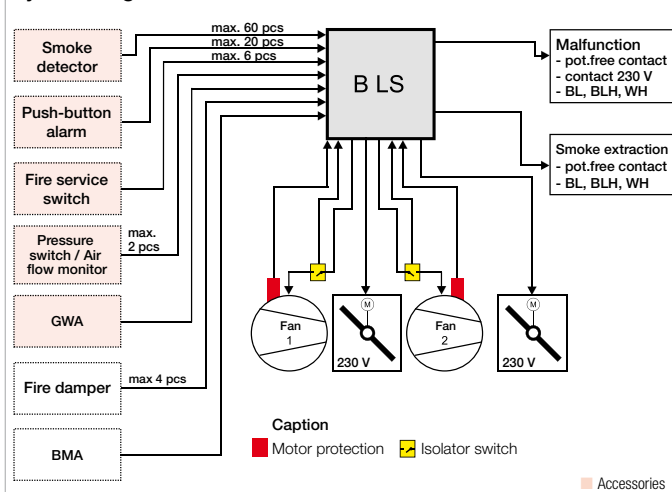

System diagram LS

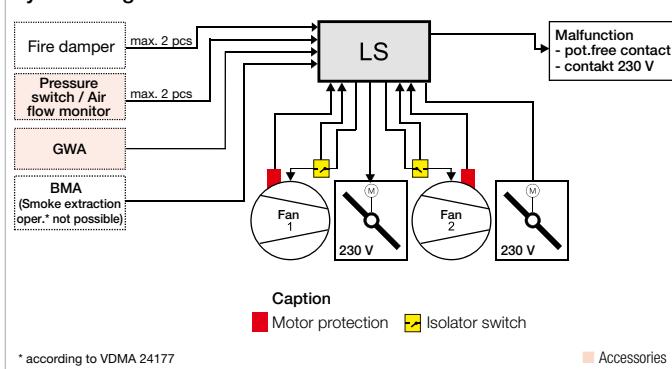

tion control system has motor protection circuit breakers. If the motor protection devices are triggered, a fault signal is transmitted which can be unlocked after cause investigation by the rotary switch for the operating mode.

- All motor protection devices for the smoke exhaust garage ventilation control system B LS are bridged in case of smoke extraction. Thus, the smoke extraction function is ensured until the destruction of the fan.

## Connection options B LS

- **Input**
  - Gas warning system
  - Fire alarm system
  - 2x fire dampers
  - 2x feedback from isolator switch
  - 60x smoke detector
  - 20x push-button alarm
  - 6x fire service switch
  - Motor monitoring by PTC thermistor (KL) or thermal contact (TK)

## Output

- 2x smoke extraction fan
- 2x 230 V damper
- Fault
  - 1x pot.-free contact
  - Contact with 230 V - potential
- Smoke extraction
- Outputs see box in diagram

## Connection options LS

- **Input**
  - Gas warning system
  - Fire alarm system (smoke extract. not possible)
  - 2x fire dampers
  - 2x feedback from isolator switch
  - Motor monitoring by PTC thermistor (KL) or thermal contact (TK)
- **Output**
  - 2x fan
  - 2x 230 V damper
  - Fault
    - 1x pot.-free contact
    - 1x flash light
  - Outputs see box in diagram

## Marking

- TÜV approval
- CE

## Accessories

### RMR Ref. no. 04984

Smoke detector according to EN 54-7, incl. detector base for the automatic triggering of system for smoke detection.

### DKM Ref. no. 04985

Push-button alarm in limit value technology for manual triggering of system by button. Includes reset button and LED indicator for operating state.

### FWS 2 Ref. no. 08255

Fire service switch (incl. LED display) with connection for DIN profile half-cylinder (Accessories).

### BL Ref. no. 08216

Flash light as 24 V signal transmitter, incl. base. Casing made of impact-resistant plastic. For ceiling and wall installation.

### Accessories:

Voltage transformer SPW 110-240 V AC / 24 V DC Ref. no. 5820

### BLH Ref. no. 04983

Flash light siren as 24 V signal transmitter, incl. base. Casing made of impact-resistant plastic. For ceiling and wall installation.

### WH Ref. no. 08217

Siren as 24 V signal transmitter, incl. base. Casing made of impact-resistant plastic. For ceiling and wall installation.

### Accessories:

Voltage transformer SPW 110-240 V AC / 24 V DC Ref. no. 5820

### DDS/DDB Ref. no. 00445/82062

Complete attachment kit for monitoring air filters, system pressure and fan operation.

### RS 3+1 Ref. no. 06387

3-pole isolator switch with auxiliary contact for fans. Plastic casing for surface-mounting.

### RS 6+1 See page 182

6-pole isolator switch with auxiliary contact for fans. Plastic casing for surface-mounting.

## Information

Isolator switch B RS in functional integrity F400 for installation within the area to be vented see p. 182