

□ 80

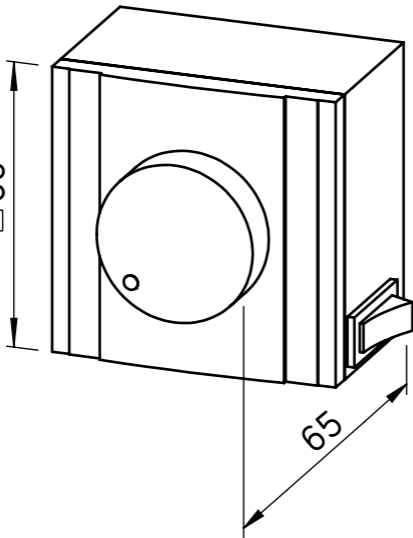

65