

LS-W EC

* bei externer Ansteuerung Brücke entfernen

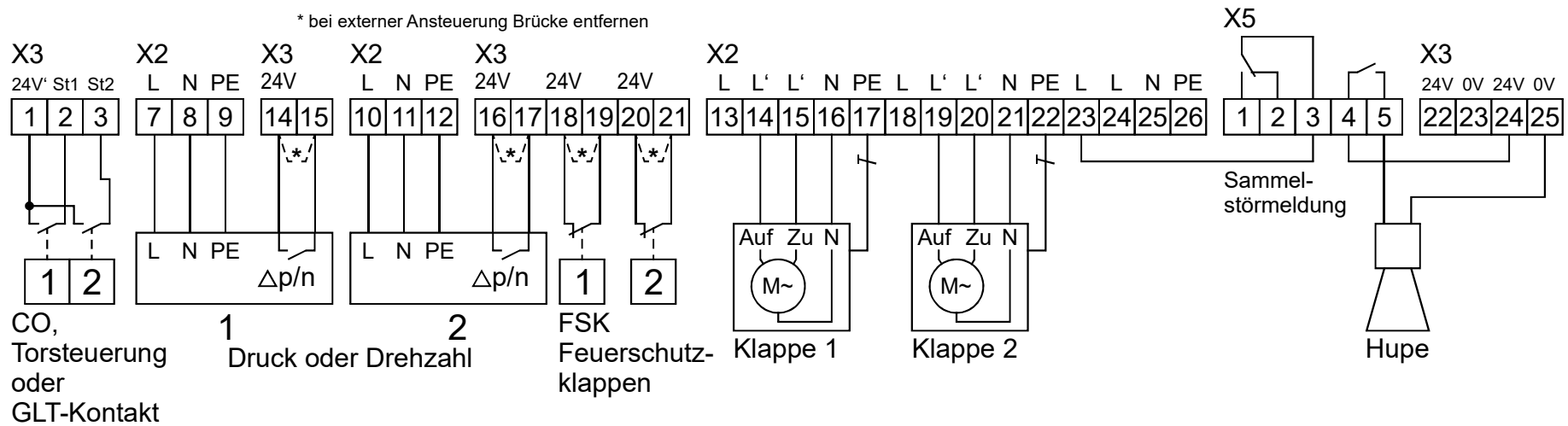

* bei externer Ansteuerung Brücke entfernen

* bei externer Ansteuerung Brücke entfernen

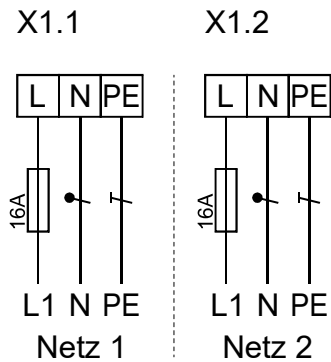

230V/50Hz

Bei nur einer Einspeisung muss ein separates Verteilergehäuse, mit entsprechenden Vorsicherungen, bauseitig gesetzt werden.

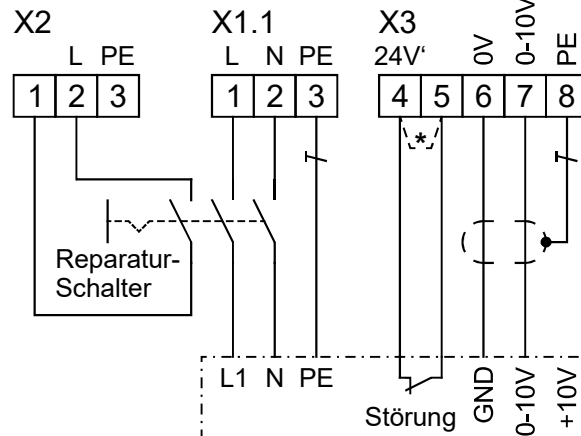

EC-Ventilator / FU-Frequenzumrichter 1

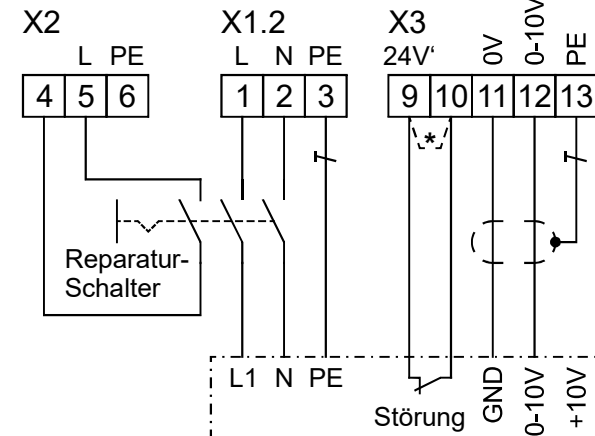

EC-Ventilator / FU-Frequenzumrichter 2

LS-W EC

* remove bridge for external control

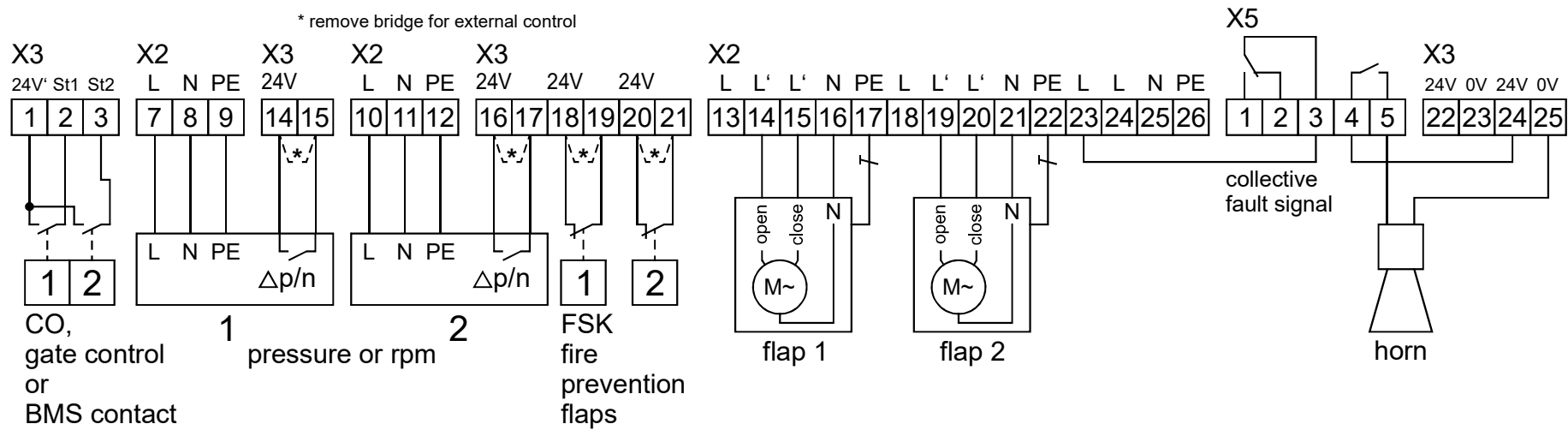

* remove bridge for external control

* remove bridge for external control

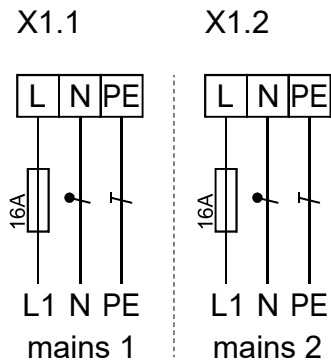

230V/50Hz

If there is only one infeed, a separate distribution box with appropriate back-up fuses must be installed on site.

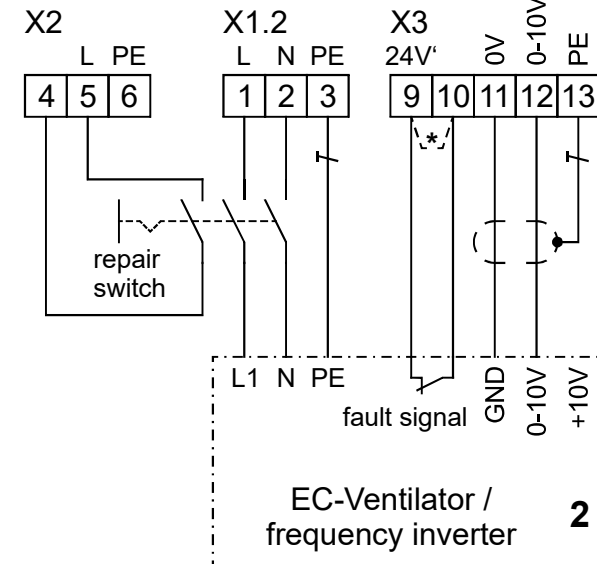
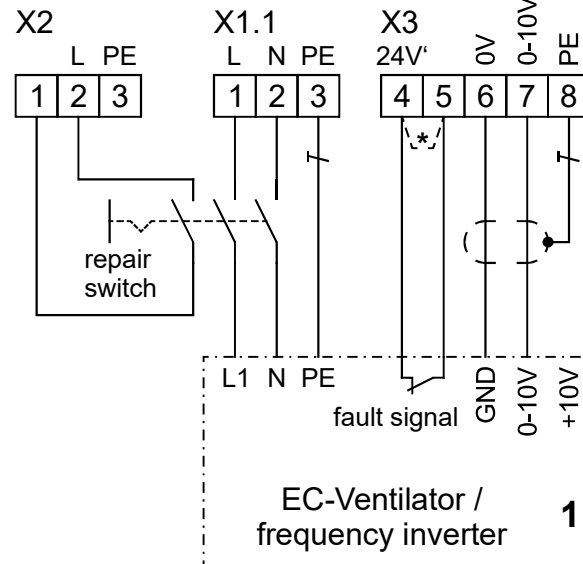

LS-W EC

* retirer le pont pour le contrôle externe

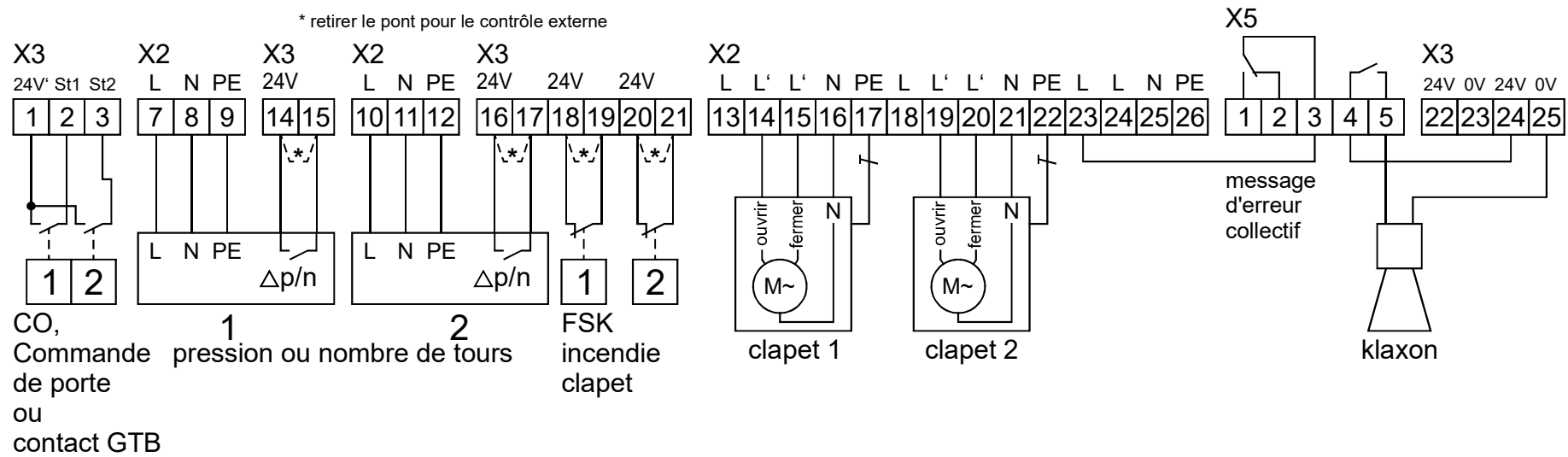

* retirer le pont pour le contrôle externe

* retirer le pont pour le contrôle externe

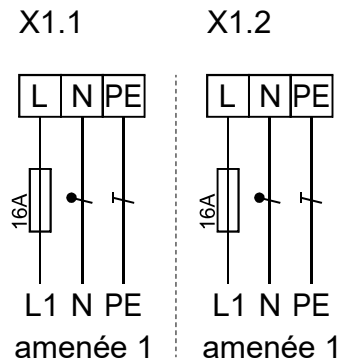

230V/50Hz

S'il n'y a qu'une seule alimentation, une boîte de distribution séparée avec les fusibles de secours appropriés doit être installée sur le site.

