

3~ 400V

z.B. Type
KVD 225/4/50/25 Ex
KVD 250/4/50/30 Ex

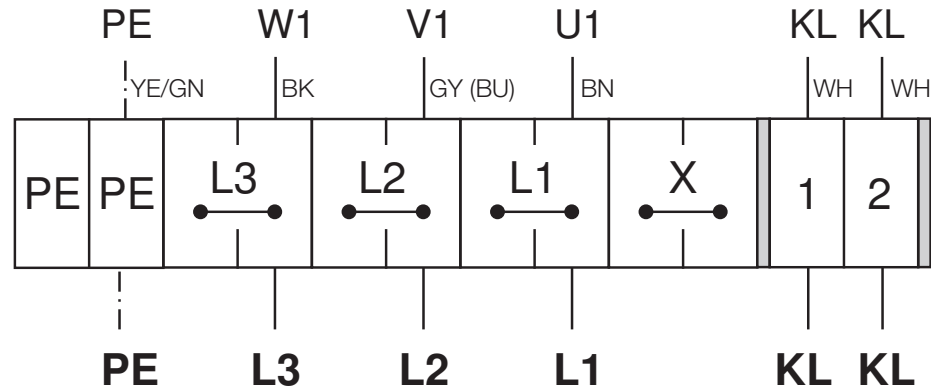

Farbcode nach IEC 757
BK-sw-schwarz-black
BN-br-braun-brown
RD-rt- rot-red
OG-or-orange-orange
YE-ge-gelb-yellow
GN-gn-grün-green
BU-bl-blau-blue
VT-vi-violett-violett
GY-gr-grau-grey
WH-ws-weiß-white
PK-rs-rosa-pink



3~ 230V/400V

z.B. Type
KVD 280/4/60/30 Ex
KVD 315/4/60/35 Ex
KVD 355/6/70/40 Ex

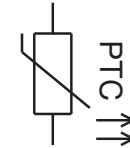
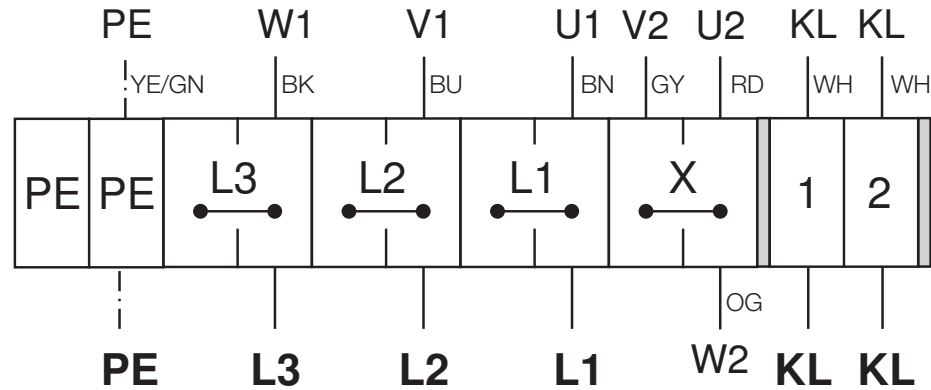

KL - Kaltleiter PTC
KL - Positive temperature coefficient thermistor PTC
KL - Thermistor PTC



3~ 400V/690V

